

POST-FRAME FIRE WALL DESIGN & CONSTRUCTION

Using the most recent 3-hour assembly with 3 layers of 5/8" gypsum board on each side

Alan Schambach, PE, SE
FBI Buildings



In virtually all jurisdictions within the United States, commercial building design is regulated by the International Building Code (IBC). Among its numerous provisions, the IBC sets allowable floor area limits (IBC Table 503) that cannot be surpassed without installing a fire suppression system or separating the area into smaller areas via the use of fire walls. In many cases, fire suppression systems are cost-prohibitive cases, so designers often utilize fire walls to comply with IBC Table 503.

The post-frame building system is a very viable construction type for commercial use. Until 2012 the go-to fire wall of choice for post-frame buildings was a CMU (concrete masonry unit) wall. Though effective, CMU walls require a concrete foundation and generally different excavation equipment and crews than typically used in post-frame building construction. This in turn adds to overall construction costs and scheduling complexity.

In previous articles, Royer and Stauffer (2012) and Shirek (2012, 2014) explained how the NFBA Technical & Research Committee worked to create a unique post-frame fire wall that would lower cost, minimize the number of different trades on a jobsite, and allow the post-frame building industry to be more competitive in the

commercial market (Figure 1.) The fruit of this effort was a 3-hour UL-approved fire wall (UL Design Number V304) wall assembly. The 2012 version of the 3-hour fire wall included 4-ply 2x6 nail-laminated columns at 8ft maximum spacing with 2x4 girts and four layers of 5/8 inch type X gypsum board per side. The wall endured the test chamber's ~1,800degree Fahrenheit temperature for 3 hours and 47 minutes before failure. The 2012 fire rated wall has served the industry adequately for several years. It should be noted that 1- & 2-hr versions of the wall are also attainable with two and three layers of drywall, respectively.

By 2018 the NFBA Technical & Research Committee was ready to embark on a new effort. Though the original wall was a significant step forward for the industry, eight layers of drywall seemed excessive. The burning question in the minds of committee members was "Could UL V304 pass the 3-hr threshold with one less layer of drywall per side?" Simple math would say that if four layers didn't last four hours, how could three layers last three hours? There was only one way to find out – run another test.

November 2018 Fire Wall Test

On November 8, 2018, several NFBA T & R Committee members attended the Underwriters



Figure 1. A 3-hour post-frame fire wall under construction.

Laboratory (UL) in Northbrook, IL to witness the test of UL V304 with 3 (instead of 4) layers of drywall per side. This test assembly was essentially the 2-hour version of the 2012 assembly, now being tested for 3 hours. Members watched the test chamber with great interest as flames took their toll on the assembly. The heat was intense, and in time wood within the wall caught fire at which point the entire chamber was filled with flames and smoke. Despite the fire now burning away at the frame of the wall, the assembly continued to hold as the clock rolled past 2 hours and 45 minutes. Suddenly, at 2 hours, 50 minutes and 23 seconds, fire broke through the remaining drywall and the test was over. Failure? At first glance, yes. The fire break-through occurred because the column had burned and lost much of its cross-sectional area which allowed it to buckle

"2-hr" or
"2 hour"

under the compression load which was 50% of the calculated design load. The committee reasoned that had the cross-sectional area of the columns been slightly greater, the test would have lasted at least 3 hours. After careful study, UL engineers agreed with this assessment, specifically certifying that UL V304 with 5-ply (instead of 4-ply) columns could be approved as a 3-hr fire wall.

Changes to UL V304

NFBA T&R Committee members were in strong agreement that adding one ply of lumber to every column was a small price to pay for the ability to reduce the 4 layers per side from the 2012 assembly to 3 layers and still maintain a 3 hour fire rating. To this end, UL V304 was updated with larger columns and less drywall. Fastener and other construction details for

continued on page: 18

is this needed for
consecutive page
layout?

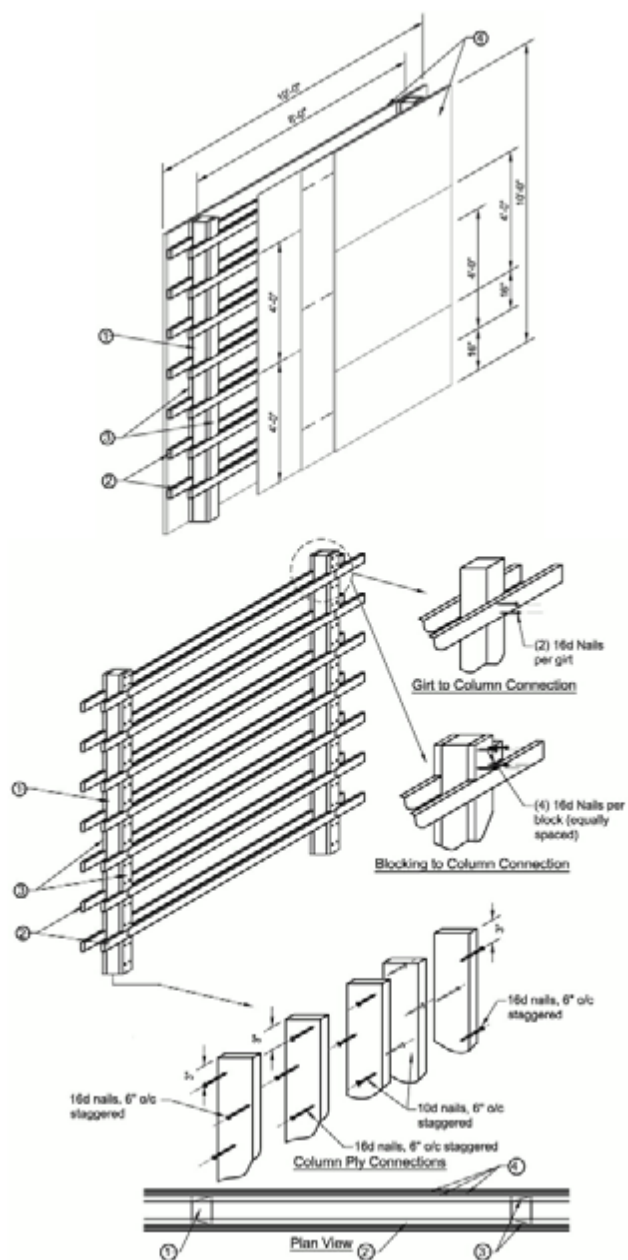

Figure 2. Construction details for a 3-hr post-frame fire wall (UL V304).

this fire wall, some of which are shown in figure 2, can be found online at <https://iq.ulprospector.com/en/profile?e=15157>. A free registration may be required to access this information.

The NFBA T&R Committee is aware of and is considering the interest of some in the industry to have glue-laminated columns included in this assembly. This option is being evaluated and may be included in future test assemblies and/or testing.

Though fire walls can exist in various forms and locations throughout a building (see Sutton, 2018), the remainder of this article only addresses fire walls running parallel to trusses, and located where there is no change in roof height (i.e., the roof height is the same on both sides of the fire wall). Fire walls that function as exterior walls are constructed similarly but have some additional code ramifications that are not covered here. Fire walls can be run perpendicular to trusses but are typically avoided due to the challenge associated with extending the wall up to or beyond the roof deck. This also will not be covered in this article.

Structural Independence

“Structural Independence” is not a phrase that is found in the IBC but is often used by engineers when discussing how a fire wall is intended to perform in the event of a fire. The phrase comes from the interpretation of the 2018 International Building Code (IBC) Structural Stability Section 706.2 which reads “Fire walls shall be designed and constructed to allow collapse of the structure on either side without collapse of the wall under fire conditions.” Earlier versions read “Fire walls shall have sufficient structural stability under fire conditions to allow collapse of construction on either side without collapse of the wall for the duration of time indicated by the required fire-resistance rating.....” To put it simply, a raging fire on one side of the wall that causes collapse of the roof structure should not be enough to pull down the wall that is intended to protect the spread of fire to other areas of the building. The code is not explicit about HOW to accomplish this, so the specifics are left to the discretion of the building engineer.

Fire Wall Framing Details

As a post-frame building engineer, with over 20 years of experience, and as one of the NFBA T&R Committee members who observed the actual fire wall testing at UL, I’ve concluded that it’s not difficult to construct the UL V304 fire wall in such a way that the stability of the assembly is maintained in

the event of a fire and roof collapse on one side of the wall. The design that I use to accomplish this is shown in Figure 3. As illustrated in the figure, there are no structural members that penetrate through the fire wall, including overhang conditions. Purlin-to-ledger connections at the top of the wall effectively behave as pin connections in that they allow for easy rotation of the roof purlin if the nearest truss were to collapse and attempt to twist the purlins off the fire wall. Consider that as a fire rages and burns up into the attic area, wood trusses and wood purlins will quickly become engulfed in flames. By the time a truss has been compromised to the point of no longer being able to support the roof as designed, surrounding purlins will also presumably have been severely compromised. And then..... whoosh!!.....the compromised roof caves in as the truss buckles and falls to the floor. I contend that as a result of the pinned purlin-to-ledger connection and fire-weakened purlins that there is not enough strength left in the collapsing system to harm the fire wall when the roof collapses. Purlins that haven't burned completely through will work to pull over the fire wall as the truss nearest the fire wall collapses. At some point, the resultant tension force in the purlins will be acting more downwards than sideways. The initial sideways pull from purlins in the collapsing roof will be resisted by purlins and roof cladding on the non-burning side of the wall and this should maintain structural stability of the fire wall. This detail has been utilized many times with no resistance from the Authorities Having Jurisdiction (AHJ).

The focus thus far has been on purlins and trusses because they are the elements that have the greatest chance of compromising the structural stability of the wall during a fire event. This is

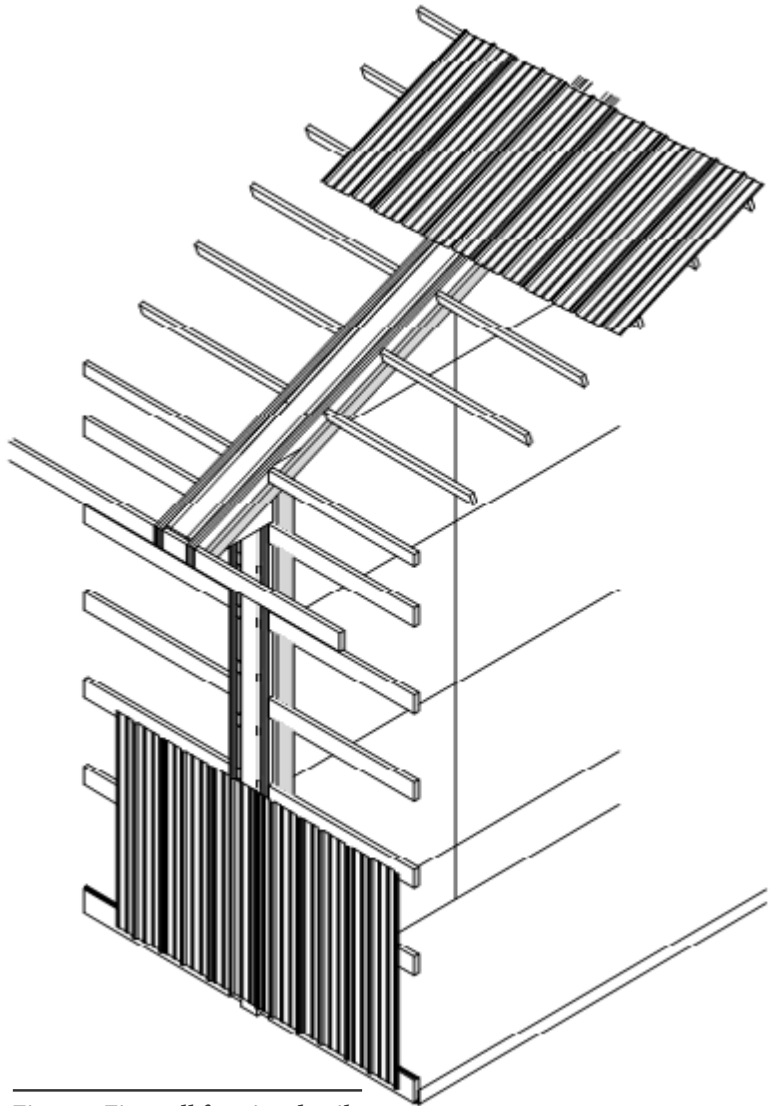

Figure 3 Fire wall framing details at roof and sidewall locations.

not to diminish the importance of proper design and construction between a fire wall and sidewalls. At such intersections, exterior girts are fastened to a vertical ledger - generally a nominal 2-inch thick member with the same depth as adjacent building columns. This ledger is attached AFTER the drywall has been installed to maintain an unbroken plane of drywall between metal panels covering opposite sides of the fire wall. It should be noted that the fire wall must continue into any architectural elements such as overhangs, mansards, etc. that cross the plane of the fire wall as well.

Pertaining to both the roof and wall intersections of the fire wall construction, the IBC permits the gypsum sheathing to terminate at the underside of non-combustible sheathing without the need for any additional sheathing or fire-resistance rating. It should be noted however that openings (windows, doors, HVAC & plumbing vents, etc.) in the roof or walls are not permitted within 4 feet of the firewall (unless another code provision is utilized).

Construction Sequencing

So how does one effectively construct a fire wall? A fire wall that is constructed prior to the rest of the building requires temporary wind bracing and protection from the elements. Conversely, if purlins, girts and cladding are installed before the fire wall, it is nearly impossible to get the fire wall built in accordance with V304 specifications. When faced with no “ideal” solutions to a particular challenge, a phrase that is often used in our office is “Pick your poison!” In other words, pick the option that has the least unfavorable conditions. Others may choose a different approach, but I have found it most effective to build the bulk of the structure first (to protect the fire wall to be constructed later) but not go so far as to create significant re-work. Note that with surrounding structure in place, fire wall column tops can easily be held in alignment with temporary bracing to nearby trusses/rafters while girts and drywall are attached to the fire wall columns.

The beautiful thing about UL V304 is that a post-frame building erection crew can construct the entire fire wall. It is recommended that, if possible, the fire wall be situated such that the nearest building trusses are approximately 4 ft from each side of the wall. This allows crews in scissor lifts to more easily install drywall in the attic area as required.

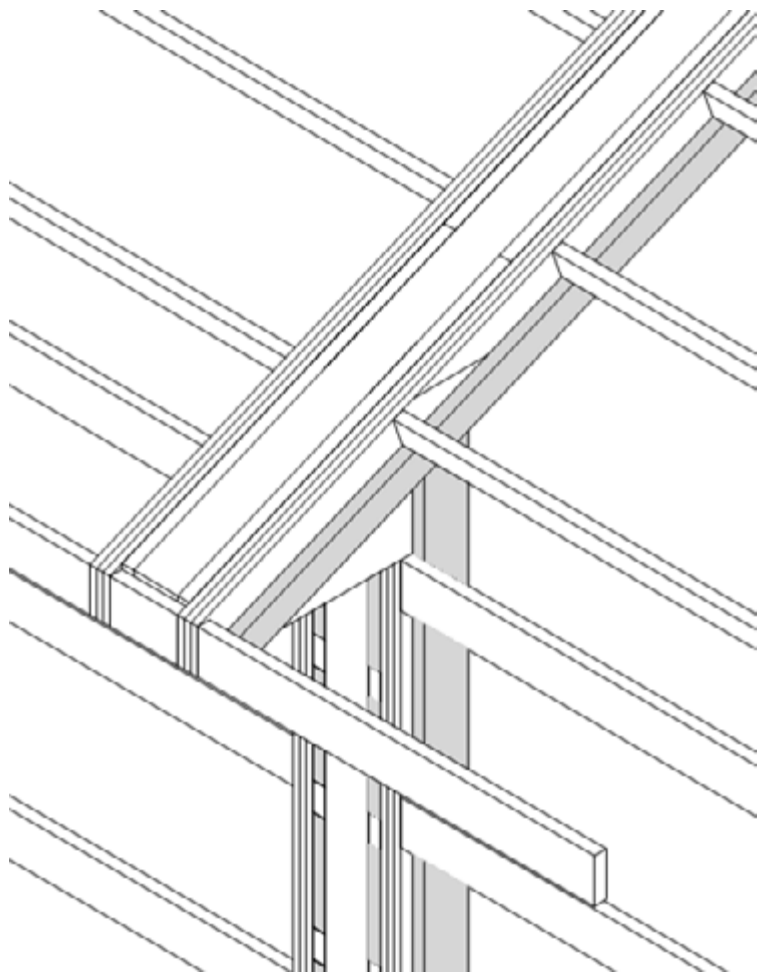

Figure 4 Closeup of purlin and girt termination.

I have found that manufacturing two trusses with 16 inch on center horizontal girts built right into the trusses, and then installing these trusses on each side of the fire wall columns slightly increases material cost but makes the framing of the wall much easier. For this reason, constructing fire wall framing while hanging trusses seems to be most advantageous.

Both the roof and walls of our post-frame buildings are generally clad with corrugated metal panels. This provides a great opportunity to construct a fire wall with minimal wasted effort. Metal panels can be laid out such that the entire roof can be clad less the panels on either side of the fire wall. Utilizing building wrap (or a material of your choosing) to weather-proof the location where metal panels are

omitted allows the crew to poke above the roof plane on a nice day and put the finishing touches at the top of the fire wall without having the roof panels to contend with. The same applies to sidewalls.

Having created an enclosed shell allows for the drywall work to begin as soon as desired. It is very important to follow the V304 specifications exactly, including drywall splicing. Starting at one corner and working across and up to the point that no more full sheets can be used will enable completion of approximately 80%-90% of the drywall work located below the roof plane. On a precipitation-free day, building wrap can be removed, and the remainder of the drywall in the truss area, up to the bottom side of the roof deck, and to the outer edges of the sidewall can be completed. Any purlins or temporary bracing running across the top of the wall must first be removed (see figure 4 for a close-up view of purlin termination). Caution is advised to do one side at a time so that the wall is never left unbraced. Cut purlins back on one side to the appropriate length such that the drywall can be slid up behind them but have enough surface bearing area to be able to connect the purlin to the ledger. After the drywall is in place and cut to the exact pitch of the roof sheeting, the ledger can be installed, and the purlins fastened down. If desired, aluminum clips or other framing hardware could be utilized to attach purlins to the fire wall. With purlins in place, the previously omitted metal panels can be installed.

The same process used for purlin installation can be used at the sidewalls where the fire wall terminates against non-combustible cladding. The building engineer should make sure that there are no openings within four feet of the fire wall if the wall is going to terminate at the underside of the non-combustible sheeting.

With drywall installed, framing properly attached, and cladding fastened into place, your own crews will have completed a cost-effective fire wall, thereby helping compress the overall construction schedule, increasing profitability

for you the builder and ultimately providing your client with the best bang for their buck.

Bibliography

- Royer, T. R. & A. Stauffer. (2012). A new post-frame fire wall: Benefits include faster assembly time and cost savings. *Frame Building News*, 24(2):58-61
- Shirek, L. (2012). "Post-frame success: Post-frame 3-hour fire wall surpasses three-hour test." *Frame Building News*, 24(2):62-63.
- Shirek, L. (2014). "NFBA attains certification for 2- and 1-hour fire-rated walls." *Frame Building News*, 26(1): 60-65.
- Sutton, R. (2018). "Basic fire wall provisions for post-frame construction." *Frame Building News*, 30(5):10-11.

About the author: Alan Schambach is a Licensed Structural Engineer and Professional Engineer and has worked for FBi Buildings of Remington, Indiana for 25 years. Alan has been a long-time active member of the NFBA's Technical and Research Committee and Editorial Review Committee and can be reached at aschambach@fbibuildings.com.

