

A NEW POST-FRAME FIRE WALL

Benefits include faster assembly time and cost savings

Commercial post-frame buildings are typically viewed as type 5 construction in the 2009 International Building Code, with size limits imposed on the allowable building area according to Table 503. These limits vary depending on the building use, geometry and site restrictions. Large building designs may require building designers to specify automatic fire-suppression systems (sprinklers), provide increased access to the perimeter of the building or subdivide the building into separate areas by using fire-rated assemblies. A sprinkler system can be very costly and impractical, and site restrictions may prohibit access to the building perimeter. The design team may choose to specify fire-rated walls or barriers to subdivide the building into smaller, code-compliant areas. This fire-rated construction can be a cost-effective way to build large post-frame buildings and maintain code compliance, especially in rural areas where access to the large amounts of water required for a properly sized sprinkler system can be financially prohibitive.

Fire walls, fire barriers and fire partitions have different purposes and requirements in the IBC. A fire wall by the IBC definition is a “fire-resistance-rated wall having protected openings, which restricts the spread of fire and extends continuously from the foundation to or through the roof, with sufficient structural stability under fire conditions to allow collapse of construction on either side without collapse of the wall.” Table 7065.4 of the 2009 IBC specifies a 3-hour rating for fire walls in occupancy groups S-1, M and F-1. These occupancies represent some of the most common commercial uses of post-frame construction. A fire wall is used to divide a single building into separate, multiple buildings

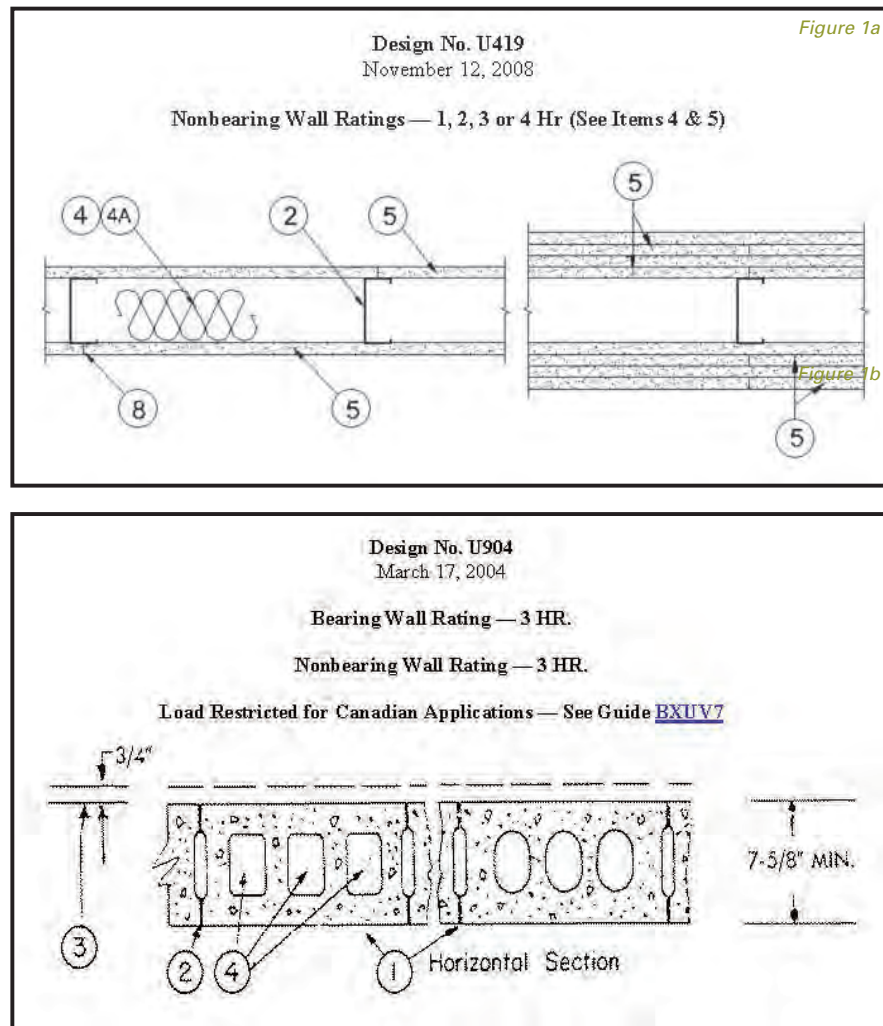

when required by the building code. Fire walls may also be used to separate a new addition from an existing building.

Fire walls must be structurally independent from the building structure on either side, though fire partitions and barriers do not have this requirement. A fire barrier is a fire-resistance-rated wall designed to restrict the spread of fire in which continuity is maintained. A fire barrier is used to create separate fire areas within a building. Fire barriers are

Figure 1. Examples of nonwood options for 3-hour fire walls: (a) steel stud and GWB assembly per UL U419 (UL, 2012a); (b) CMU fire wall per UL U904 (UL, 2012b). Detailed information for these designs can be found on the UL website; see References. Reprinted from the Online Certifications Directory with permission from UL. Copyright © 2012 UL LLC.

also used when fire separation between mixed occupancies and use groups is required by Chapter 5 of the IBC. A fire partition is a vertical assembly of materials designed to restrict the spread of fire. A fire partition is used to separate dwell-



Figure 2a



Figure 2b

Figure 2.
Small-scale test conducted at the
Forest Products Laboratory

ing and sleeping units within a building, to separate tenant spaces in covered mall buildings and to enclose egress paths.

In post-frame construction (IBC type 5 construction), fire walls are permitted to be of any approved combustible or noncombustible material as long as the construction meets the required fire-resistance rating required by Table 706.4. Prior to the approval of the post-frame 3-hour rated fire wall, only non-wood assemblies constructed using concrete masonry units, or steel studs with type X gypsum wall board on both sides were available to designers. Underwriters Laboratories design numbers U419 and U904 (see **Figure 1**) are examples of 3-hour wall designs utilizing steel studs and CMUs (see UL, 2012a, 2012b, for details on the designs).

The National Frame Building Association, with funding from the Post-Frame Marketing Initiative, contracted UL to test a 3-hour post-frame fire-wall assembly under the direction of NFBA's Technical and Research Committee. In 2010 the T&R Committee formed a subcommittee to explore the possibility of creating a code-compliant post-frame 3-hour fire wall. This committee contracted Robert White, PhD, of the Forest Products Laboratory to prepare and test several small assemblies to determine the best combination of wood framing and GWB for this fire wall (see **Figure 2**). The committee also worked with Kuma Sumathipala, PhD, of the American Wood Council to determine calculated estimations of fire performance on sev-



Figure 3a



Figure 3b

Figure 3.
Full-scale post-frame fire-wall testing.

eral different combinations of framing and GWB. Some options considered by the committee included post type, spacing and size, wall girt spacing, size and orientation, thickness, type and number of layers of GWB, fastening and layering of the GWB and fastening of all components in the tested assembly. Another consideration was to test a load-bearing and a non-load-bearing wall and the amount of load the wall will resist. The result of small-scale testing, calculated values and much discussion by the committee was a recommended assembly to be tested by a code-approved laboratory with post-frame wall construction and four layers of 5/8-inch type X GWB on each side with a predetermined bearing load according to ASTM E119.

In September 2011 NFBA contracted with UL to perform full-scale testing on the assembly and provide code-accepted test results for use by the design community (see **Figure 3**). This test was completed in December 2011 and is now available for use. The approved assembly is listed as UL Design Number V304 and is bearing wall rated at 3.5 hours.

Posts, girts, wood blocking and GWB are described in this listing along with the assembly construction and connections (see **Figure 4**). The full design is available in the UL database; see UL, 2012c.

The benefits of specifying and installing the new post-frame fire wall are many. The “structurally independent” requirement is easily met because each post provides independent support for the wall. The wall designer may utilize typical post-frame foundations to eliminate the need for a continuous footing and foundation wall. Another benefit is that post-frame builders will no longer need concrete masonry or steel material or specialty tradespeople to build fire walls. This will allow the same crew that constructs the post-frame building to assemble the fire wall, allowing faster construction time and saving money. **Figure 5** is a design example from a post-frame building project that was designed and built several years ago and required a 3-hour fire wall because of the overall size of the building. The building was classified in the S-1 use group, with the proposed use of the building being stor-

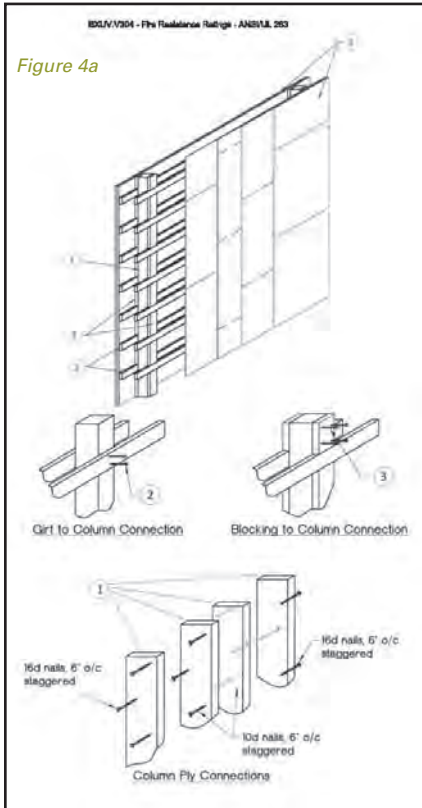

Figure 4a

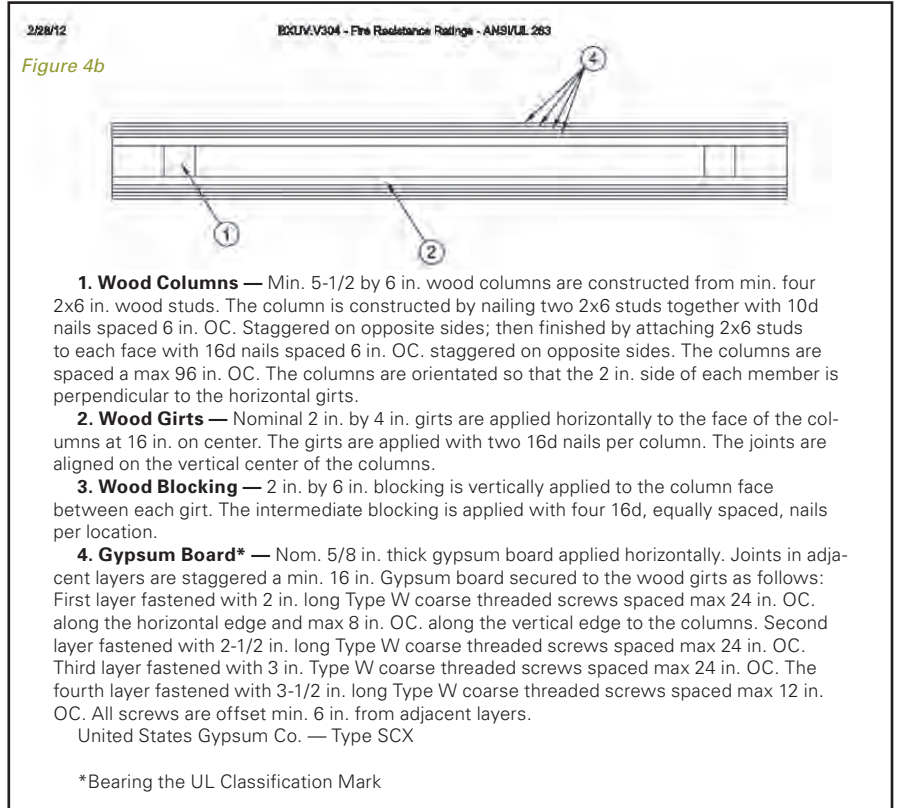

Figure 4b

- 1. Wood Columns** — Min. 5-1/2 by 6 in. wood columns are constructed from min. four 2x6 in. wood studs. The column is constructed by nailing two 2x6 studs together with 10d nails spaced 6 in. OC. Staggered on opposite sides; then finished by attaching 2x6 studs to each face with 16d nails spaced 6 in. OC. staggered on opposite sides. The columns are spaced a max 96 in. OC. The columns are orientated so that the 2 in. side of each member is perpendicular to the horizontal girts.
- 2. Wood Girts** — Nominal 2 in. by 4 in. girts are applied horizontally to the face of the columns at 16 in. on center. The girts are applied with two 16d nails per column. The joints are aligned on the vertical center of the columns.
- 3. Wood Blocking** — 2 in. by 6 in. blocking is vertically applied to the column face between each girt. The intermediate blocking is applied with four 16d, equally spaced, nails per location.
- 4. Gypsum Board*** — Nom. 5/8 in. thick gypsum board applied horizontally. Joints in adjacent layers are staggered a min. 16 in. Gypsum board secured to the wood girts as follows: First layer fastened with 2 in. long Type W coarse threaded screws spaced max 24 in. OC. along the horizontal edge and max 8 in. OC. along the vertical edge to the columns. Second layer fastened with 2-1/2 in. long Type W coarse threaded screws spaced max 24 in. OC. Third layer fastened with 3 in. Type W coarse threaded screws spaced max 24 in. OC. The fourth layer fastened with 3-1/2 in. long Type W coarse threaded screws spaced max 12 in. OC. All screws are offset min. 6 in. from adjacent layers.
United States Gypsum Co. — Type SCX

*Bearing the UL Classification Mark

Figure 4. Design No. V304 (January 20, 2012): Newly approved post-frame and GWB fire wall, 3.5-hour rated assembly, with construction details and notes corresponding to items 1-4. Reprinted from the Online Certifications Directory with permission from UL. Copyright © 2012 UL LLC.

age units. The overall size of the building was 72 x 210 feet for a total area of 15,120 square feet. Due to restrictions of the project building site, the allowable area increase due to open perimeter was not able to be applied. The options were

to either divide the building into separate buildings with a fire wall or install an automatic sprinkler system. The fire wall was the more cost-effective option. A 10-inch CMU wall was selected for the fire wall because at the time of design

the only fire-wall options available were CMU or steel. In this example, the wall extended up to the underside of the decking per Section 706.6, Exception 4, of the 2009 IBC. The termination of the wall at the roof line can be seen in Figure 6.

Figure 5. Example of a post-frame building with a 3-hour CMU fire wall.

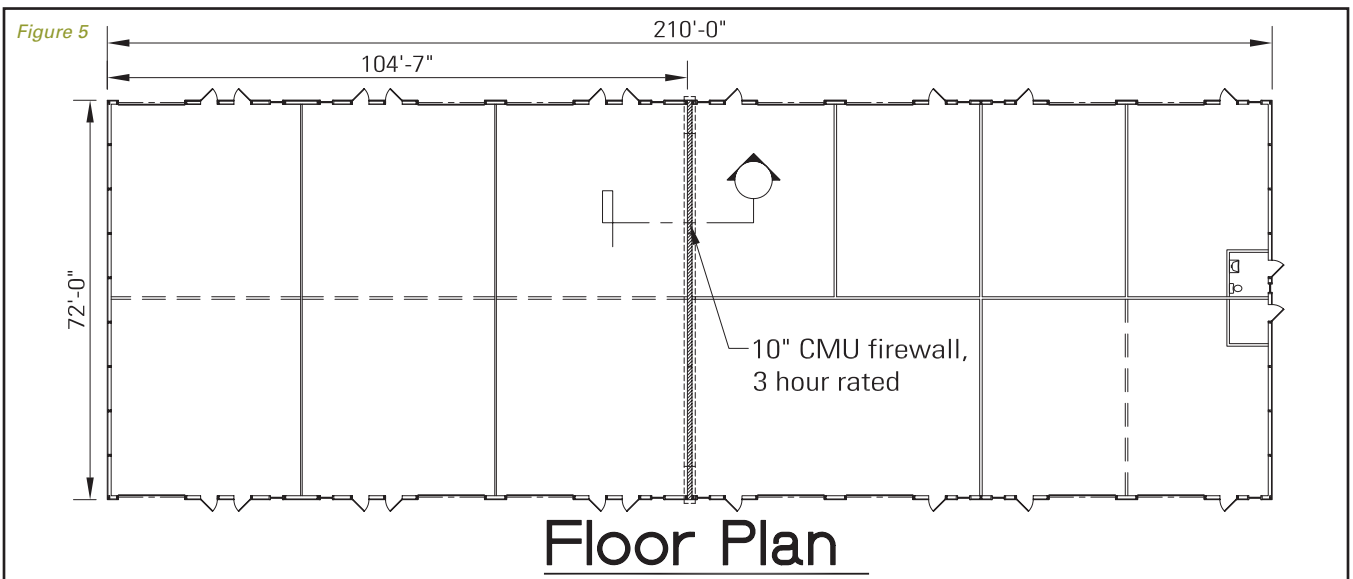

Floor Plan

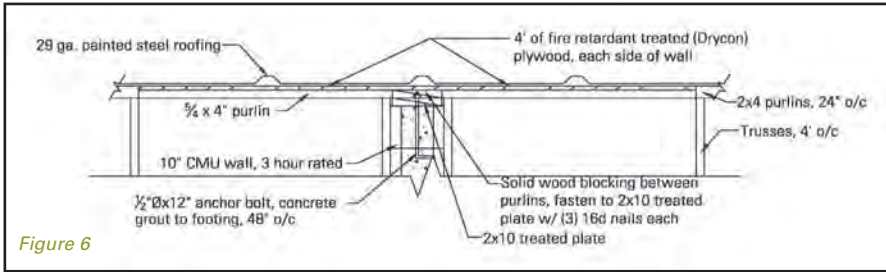

Figure 6

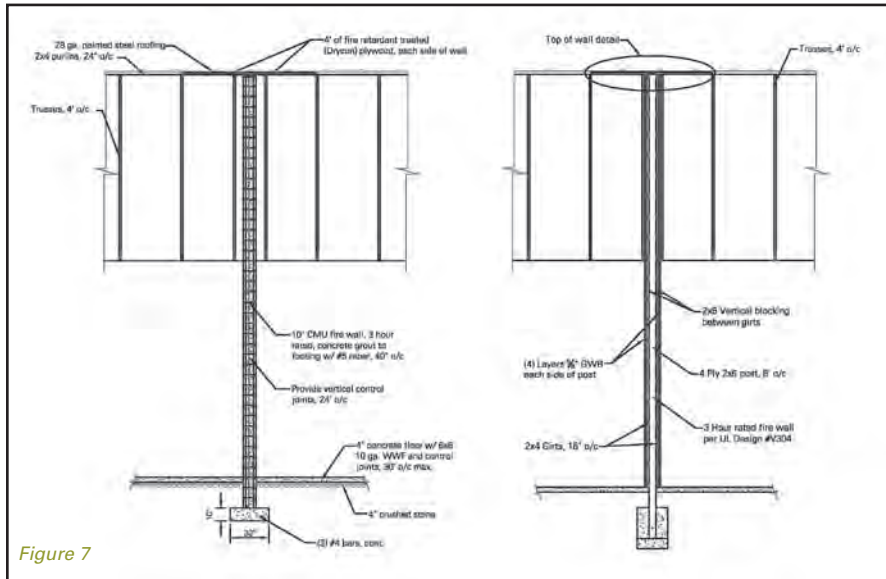

Figure 7

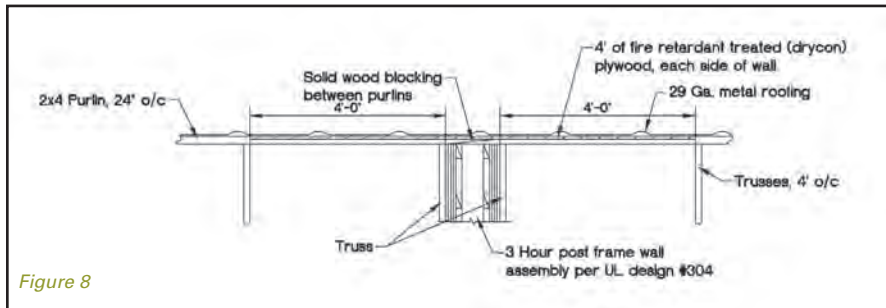

Figure 8

The details in Figures 6–8 show a comparison between the actual 10-inch CMU wall that was installed in this project and the newly available post-frame fire wall. The details have been provided by Timber Tech Engineering and have been used as code-compliant design solutions in past projects. Other variations of these details exist and may be acceptable. The CMU wall design in this example required solid grout and rebar to the footing every 40 inches with a large continuous reinforced concrete footing. Vertical control joints were also required in the block wall. Utilizing the post-frame fire wall would have required no continuous concrete footing or CMU.

Figure 8. Detail for top of wall termination with UL Design Number V304.

This would have minimized cost because masonry materials and tradespeople would not have been needed, and the amount of poured concrete would have been reduced because of the individual post footings. The construction of the post-frame wall shown in Figure 7 consists of 4-ply 2x6 posts spaced 8 feet on center with 2x4 girts on both sides. The posts have their own individual typical post-frame footings. Vertical solid blocking is required between the girts on each side of the post similar to fire blocking as required by the IBC. Four layers of 5/8-

Figure 6. Detail for top of CMU wall termination.

inch type X GWB are applied on each side over the girts. This design would have been the most cost-effective choice for this project if the post-frame fire-wall assembly UL V304 had been available when this project was designed.

Not only will the approval of this 3.5 hour post-frame fire wall be beneficial to designers and contractors, it is an important development for the entire post-frame industry. Post-frame builders will now be able to frame the entire structure of large commercial projects, including the fire walls, making post frame a more viable option for bigger buildings. With its ability to reduce construction costs and ease of structural independence, UL Design Number V304 is a valuable addition to a post-frame designer's arsenal.

Figure 7. Cross-section through fire wall (CMU vs. post frame).

Royer is president of Timber Tech Engineering, Inc., Denver, Penn. Stauffer is a code specialist and draftsman at Timber Tech Engineering, Inc., Denver, Penn. **FBN**

References

International Code Council. (2009). International building code 2009. Country Club Hills, IL: International Code Council.

Underwriters Laboratory. (2012a). Design No. U419. Online certifications directory. Retrieved March 2, 2012, from <http://database.ul.com/cgi-bin/XYV/template/LISEXT/1FRAME/showpage.html?name=BXUV>. U419&ccnshorttitle=Fire+Resistance+Ratings+-+ANSI/UL+263&objid=1074330521&cfgid=1073741824&version=versionless&parent_id=1073984818&sequence=1.

Underwriters Laboratory. (2012b). Design No. U904. Online certifications directory. Retrieved March 2, 2012, from <http://database.ul.com/cgi-bin/XYV/template/LISEXT/1FRAME/showpage.html?name=BXUV>. U409&ccnshorttitle=Fire+Resistance+Ratings+-+ANSI/UL+263&objid=1074330471&cfgid=1073741824&version=versionless&parent_id=1073984818&sequence=1.

Underwriters Laboratory. (2012c). Design No. V304. Online certifications directory. Retrieved March 2, 2012, from <http://database.ul.com/cgi-bin/XYV/template/LISEXT/1FRAME/showpage.html?name=BXUV>. V304&ccnshorttitle=Fire+Resistance+Ratings+-+ANSI/UL+263&objid=1082185782&cfgid=1073741824&version=versionless&parent_id=1073984818&sequence=1.