

Post connection engineering

Understanding the forces at work in structural framing

By David R. Bohnhoff, Ph.D., P.E.
University of Wisconsin-Madison

Over the past couple years I have been asked an increasing number of questions that relate to the rigidity of various post-to-truss connections and post-to-concrete connections.

I attribute this ramped interest in connections to (1) an increase in the number of posts attached to concrete slabs, piers and walls, (2) use of the post-frame system in an increasing number of commercial/industrial buildings (i.e., code-compliant applications), (3) greater reliance on diaphragm action in buildings, and (4) connection-related research conducted at the University of Wisconsin-Madison.

This article will discuss what is meant by the rigidity of a connection and its relative importance in overall building design. I also have some examples of connections that I have recently fabricated. As a means of introduction to this material, it is helpful to first understand the forces at work in structural framing members.

Forces in structural framing members

When loads are applied to a building, stresses are induced in the various structural framing members that comprise the building. These stresses vary from location to location within the members. If you were able to cut through a member, and then measure and plot the stresses acting along the cut surface, your plot may appear like the one shown in **Figure 1a**, where the length of each arrow represent the magnitude of the resultant stress at that point on the surface, and the direction of the arrow represents the direction at which that resultant stress acts.

The net effect of the stresses acting on a cut surface can be represented by a single, equivalent force as shown in **Figure 1b**. The magnitude and direction of the stresses will determine the magnitude of this force, and the direction and magnitude at which it acts. In

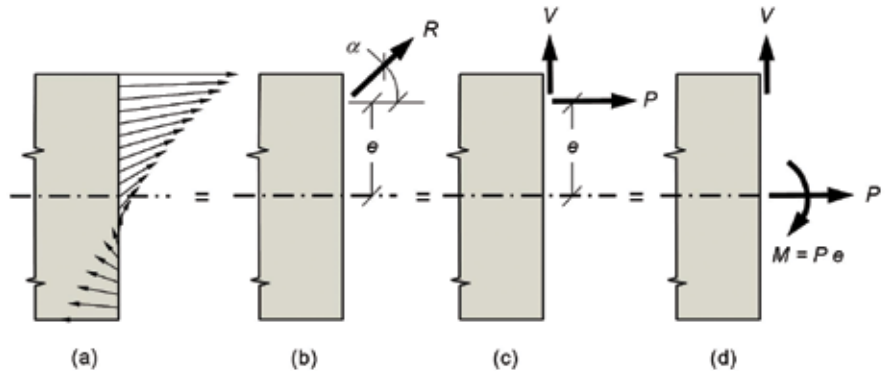

Figure 1. Distribution of stress on the cut surface of a member (a), and equivalent force distributions (b), (c) and (d).

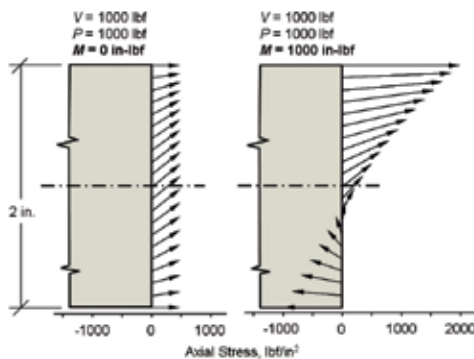

Figure 2. Affect of changes in bending moment on axial stress distributions in a rectangular member 1 inch wide and 2 inches deep.

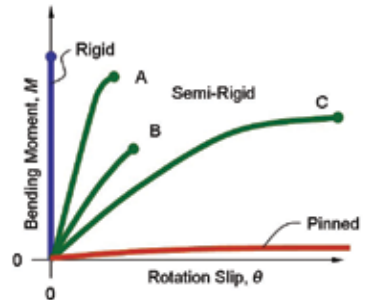

Figure 3. Categorization of a connection based on the relationship between the bending moment transferred by the connection and the rotational slip between the members being connected.

figure 1b, the location at which the force acts is shown as the distance e measured from the centroid (a.k.a. center of mass) of the cut surface. Note that the angle α is the direction of the equivalent force, and the direction that the other part of the member will want to move when the member is cut.

To simplify things for structural analyses, engineers convert the resultant force into two components: a shear force V which acts parallel to the cut surface, and an axial force P that acts normal (i.e., perpendicular) to the cut surface (**Figure 1c**). When the location of axial force P does not coincide with the centroid of the member (i.e., when e is non-zero), the member will bend. To account for this, the axial force P acting at a dis-

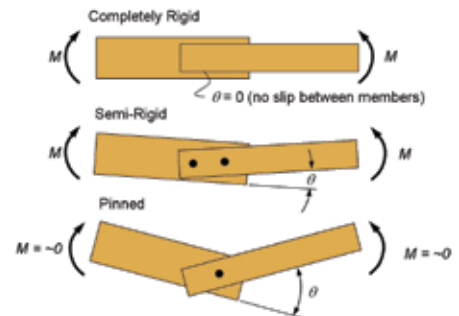

Figure 4. Categorization of connections by rotational stiffness.

tance e from the centroid is replaced with: (1) an axial force P located at the centroid, and (2) a bending moment M that is numerically equal to “ P ” times “ e ” (**Figure 1d**).

When comparing figures 1a and 1d, it

is apparent that the stresses acting along the cut surface of any member can be represented with a shear force V that acts parallel to the cut surface, an axial force P that is applied at the centroid of the surface and acts normal to the surface, and a bending moment M . If a designer sizes a member so that it can handle these three forces, that member should not fail.

Of the three components in figure 1d, bending moment M is generally of greatest concern. When bending moment is present in any significant amount, it will generally dictate the size, and often the shape of a member. Under a pure bending moment, stresses in a member are maximum at the outer edges of the member and decrease to zero at the member's centroid. This means that the material near the centroid of the member is doing very little to resist the bending moment (i.e., it is being used very inefficiently).

Figure 2 shows how the stresses on the cut surface of the rectangular member become much more uniform when bending moment is reduced to zero. To counter bending moment, members are made deeper and/or more material is concentrated toward the outer edges of the member where it is more effective. The latter approach explains the use of I-shaped members.

Connection classification

Properly designed connections are just as important to overall structural integrity as properly sized structural framing members. To this end, a clear understanding of the strength and stiffness of connections is extremely important. Unfortunately, the design community at large has a history of ignoring connections, which has invariably resulted in a majority of building failures being triggered by under-designed or compromised connections.

For structural analysis purposes, connections are classified according to their rotational stiffness. Rotational stiffness is the ratio of the bending moment M being transferred by a connection to the corresponding rotational slip between the members joined by the connection. Figure 3 contains a plot of applied bending moment M versus rotational slip. Numerically, rotational stiffness is equal

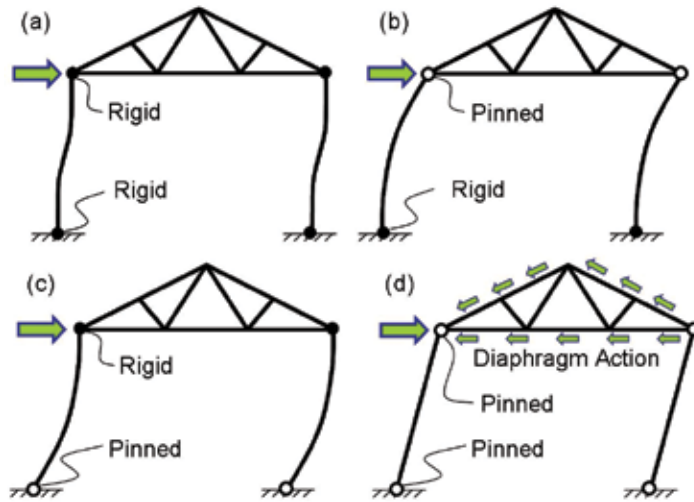

Figure 5. Influence of post connection type on post-frame behavior.

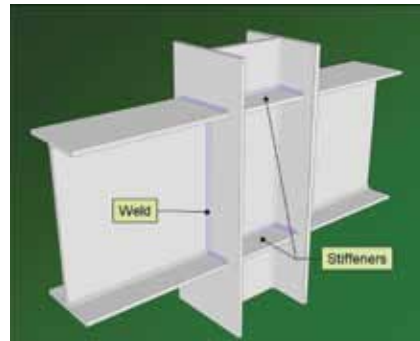

Figure 6. Rigid connection between intersecting steel wide flange (WF) I-beams.



Figure 7. Rigid connection between steel trusses.

to the slope of the curves in this figure.

As indicated in Figure 3, a *rigid* connection is one in which there is no rotational slip between connected members when bending moment is transferred between the members. A *semi-rigid* connection is one in which there is some slip between members when bending moment is transferred between them. Finally, a *pin* connection is one incapable of transferring bending moment between members. Any attempt to transfer even the slightest amount of bending moment through a true pin connection will result in measurable rotation between the members. In this respect, a pin connection behaves as a simple hinge.

Figure 4 illustrates the three basic categories of connections. Although no connection behaves as a true pin connection because of friction, a single dowel-type fastener (e.g., a nail, bolt or screw) connecting two wood members comes very close. Two wood members that are

properly surfaced, glued together with a very stress-resistant adhesive (e.g., resorcinol resin, phenol resin), and then cured under pressure, will form a joint that for all practical purposes behaves as a rigid joint. The majority of wood member connections would be classified as semi-rigid connections. This includes those with multiple dowel-type fasteners, and those featuring metal plate connectors (a.k.a. metal truss plates).

The impact of a semi-rigid connection on overall structural behavior can be studied once the relationship between applied bending moment and rotational slip for the connection (Figure 3) has been established, typically by laboratory testing. When loaded to failure, a connection test provides the ultimate bending strength of the connection in addition to its rotational stiffness.

Ultimate bending strength is represented by the dots at the end of the curves in Figure 3. It is important to note that just because one connection

may have a greater rotational stiffness than another, it may not have a higher bending strength. In Figure 3, connection B is stiffer than C, but C is stronger than B.

In the absence of data defining the rotational stiffness of a connection, it is often best for the engineer to analyze the structure twice — once with the connection treated as a pin type connection, and once with the connection treated as a completely rigid connection. The true behavior of the structure will lie somewhere between these two extremes. This is referred to as “bracketing” the solution.

Importance of bending moment transfer by connections

Figure 5 shows how the rotational stiffness of connections affects the stiffness of a post-frame comprised of a gable truss supported on each end by a single post. In this example, we look at the two extremes: frictionless pin and completely rigid connections.

If truss-to-post connections can be either pinned or rigid, and post-to-foundation connections can be either pinned or rigid, the four combinations shown in figure 5 are possible. The stiffest of these four combinations — the one which will sideway the least under horizontal loadings — is obviously the one with rigid post-to-truss and rigid post-to-foundation connections (Figure 5a). In fact, if a horizontal load is applied to the truss, the movement of the post-frame with all rigid connections will only be one-fourth of that for a post-frame under the same loading in which either the truss-to-post connection is pinned (Figure 5b) or the truss-to-foundation connection is pinned (Figure 5c). If all post-frame connections are pins (Figure 5d) the frame must rely entirely on engineered diaphragms and accompanying shearwalls to resist horizontally-applied forces.

Not only does post-frame sideway decrease as connections are made more rigid, but the distribution of bending moments within the posts almost always becomes more uniform. Most importantly, maximum post bending stresses are reduced resulting in an increased factor of safety. In some cases, the stress reduction is enough to warrant a reduc-

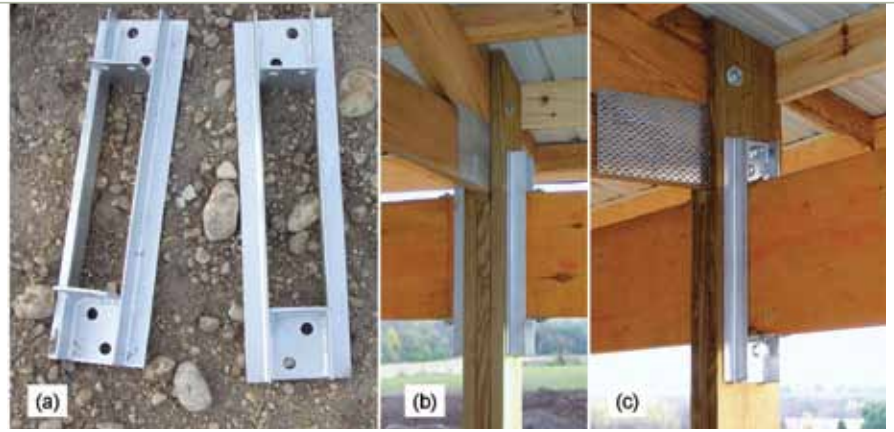

Figure 8. Steel brackets (a) used to LVL headers to a posts (b) and (c).

tion in post size.

In situations where diaphragms are employed to transfer all roof and upper wall loads to shearwalls, it is still beneficial to design post connections with an ability to transfer bending moment even though post ends could be pin-connected. Again, making the connections more rigid will generally reduce maximum post stresses enabling a possible reduction in post size. Rigid connections also provide an alternate path for load transfer should diaphragm or shearwall strength or stiffness be compromised.

Toward more rigid connections

As the previous example demonstrates, it is advantageous to construct connections so that they have more rotational stiffness. That said, it is important to realize that if you construct a connection so that it has more rotational stiffness, that connection will attract more bending moment, and thus must be simultaneously designed to handle the additional bending moment.

Generally, the most efficient way to transfer bending moment between two members is to directly connect the highly stressed areas in one member to the highly stressed areas of another member. Since stress due to bending moment is concentrated on the outer edges of a framing member (Figure 2), efficient transfer of bending moment means directly connecting the outer edges of one framing member with the outer edges of the other framing member.

Two examples of “moment” connections with steel members are shown in Figures 6 and 7. With steel I-beams (Figure 6), direct transfer of bending

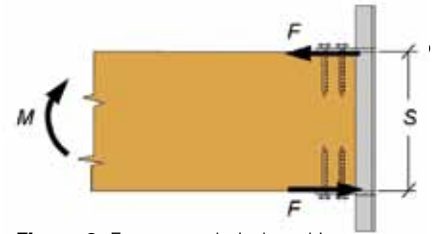

Figure 9. Force couple induced in lag screws of the figure 8 connection by bending moment M .

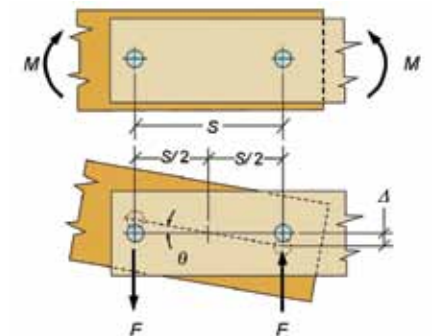

Figure 10. Force couple and associated rotation induced in a lap joint by bending moment M .

flanges. Where separation of flanges does not enable direct connection, special plates are welded between the flanges. In figure 6, stiffeners welded between the flanges of the vertical I-beam help transfer flange forces from one horizontal beam to the flanges of the other horizontal beam, as well as from the flanges of a horizontal beam to the flange on the opposite side of the vertical I-beam.

In Figure 7, a moment connection is achieved between the ends of steel trusses by providing a fairly direct and rigid connection between the chords of opposing trusses.

Figure 8b shows a connection between two laminated veneer lumber (LVL) headers and a mechanically-laminated



Figure 11. Four different post-to-truss connections: (a) regular heel truss with kneebrace, (b) raised heel truss, (c) deep heel truss, and (d) regular heel truss without kneebrace.

post. As this figure shows, the steel brackets are connected to the LVL headers with lag screws anchored into the top and bottom of the headers. Four bolts are used to attach the two steel brackets to the post. These bolts not only transfer vertical loads from the headers into the

post, but they also transfer horizontal forces between the two headers, and lock the truss into place between the outer plies of the post.

I designed the connection in Figure 8 for my brother's heifer barn. Although it is similar in appearance and function to the steel connection in Figure 6, I did not specifically engineer it to be a moment resisting connection as I did not need additional rotational strength and stiffness.

In fact, as a few of my fellow post-frame building engineers have pointed out, my connection isn't all that great when it comes to moment resistance. This is because connections involving larger diameter fasteners (i.e., lag screws and bolts) installed parallel to the glue-lines (i.e., into the narrow face) of an LVL are more prone to splitting than connections with the same fasteners installed in the narrow edge of solid-sawn lumber. To this end, before the system in Figure 8 could be used in applications requiring building code compliance, the lag screw

connection would need to be tested to determine its shear strength and shear stiffness.

Once the shear strength and stiffness of the lag screw connection has been determined, the bending strength and rotational stiffness of the entire header-to-steel bracket connection can be determined. As shown in Figure 9, the moment applied to each header is resisted by a "force couple" that results when the moment tries to shear the lag screws at the interfaces (a.k.a. shear planes) between the steel bracket and header.

Dimension S in Figure 9 is the spacing between the shear planes. The shear force F induced in each set of lag screws is numerically equal to bending moment M divided by spacing S . Consequently, as spacing S increases (i.e., the depth of the header increases), shear force F decreases. The rigidity of the connection is largely dependent on how much slip occurs at the shear planes under the shear force F (i.e., the slip of the lag screw connection).





Improve the quality of your next post frame building by specifying Glu-Lam Posts





Advantages of Glu-Lam Posts

- Stronger
- Straighter
- Superior Treatment
- Economical

Richland, PA 17087
 Phone: (717) 866-6581 Fax (717) 866-7237
 Oakland, MD 21550
 Phone: (301) 334-3977 Fax (301) 334-9289
www.rigidply.com

Circle Reader Service #382

Table 1 Edge and End Distances and Spacing Requirements for Bolts and Lag Screws (AF&PA, 2005)

Loading Direction	Measurement	Characteristic*	Minimum Dimension Required to Develop Full Fastener Resistance**
Parallel to Grain	Edge distance	$L_m/D \leq 6$	1.5D
		$L_m/D > 6$	Greater of 1.5D or 1/2 gage spacing perpendicular to grain
	End distance	Tension member	7D for softwoods 5D for hardwoods
		Compression member	4D
	Spacing	Pitch (parallel-to-grain)	4D
Gage (perpendicular-to-grain)		1.5D < 5 inches	
Perpendicular to Grain	Edge distance	Loaded edge	4D
		Unloaded edge	1.5D
	End distance		4D
	Spacing	Pitch (perpendicular -to-grain)	Limited by requirements of attached members
		Gage (parallel -to-grain) $L_m/D \leq 2$ $2 < L_m/D < 6$ $L_m/D \geq 6$	2.5D (5L _m + 10D)/8 5D

* D is fastener diameter. L_m is defined as the lesser of (a) the length of the fastener in the main member, or (b) the total length of the fastener in the side members. The main member is the center member in a three-member connection or the wider member in a two-member connection. Pitch is the spacing of fasteners within a row, and gage is the spacing between rows of fasteners.

** Distances are measured from the center of the bolt or screw. If a spacing/distance does not meet the stated requirement, the design capacity of the fastener must be reduced in accordance with the AF&PA NDS.

Since slip decreases as *F* decreases, and *F* decreases as *S* increases, a deeper header will result in a more rigid connection. Slip can also be reduced (and rotational stiffness increased) by adding more lag screws at each shear plane. Adding more lag screws also increases the overall bending strength of the connection. In all cases, it is important to maintain proper fastener spacing and edge distance to reduce likelihood of wood splitting.

The efficiency and practicality of attaching brackets to the outer edges of wood framing members for bending moment transfer (as shown in **Figures 8 and 9**) generally depends on mechanical fastener properties and space limitations. For many wood framing applications, it is more efficient and practical to simply lap the framing members as shown in **Figure 4**, and connect them with adhesive, mechanical fasteners or both. When a pair of mechanical fasteners is

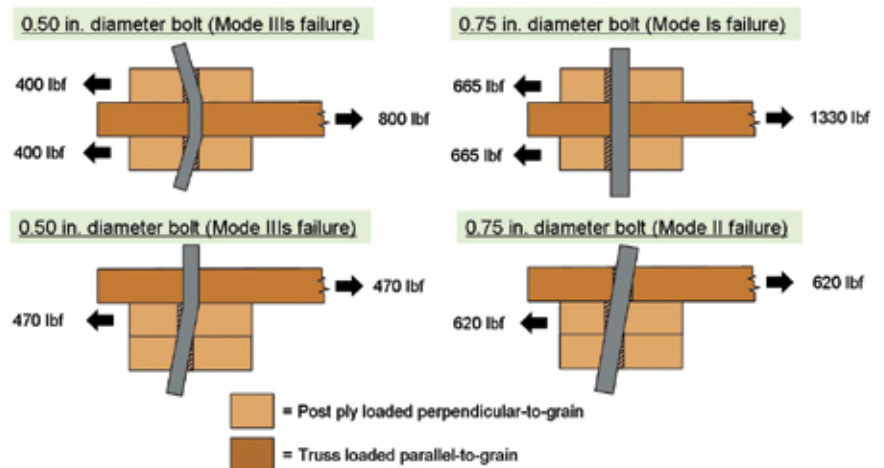

Figure 12. ASD bolt connection capacities for normal load duration. Wood specific gravity assumed equal to 0.55 and bolt bending yield strength set equal to 45,000 lbf/in².

used (**Figure 10**) the force *F* induced in each fastener by bending moment *M* is again equal to the magnitude of the bending moment divided by the spacing *S* between the “force couple”. The

force *F* causes a slip Δ between the wood members. The ratio of force *F* to slip Δ is the shear stiffness *k* of the fastener. Dividing slip Δ , by half the spacing *S* yields the rotation θ of the connection.

In equation form, these relationships can be expressed as:

$$M = F S$$

$$k = F/\Delta$$

$$\Delta = \square S/2$$

From these equations the following relationship for the rotational stiffness M/\square of the connection can be obtained.

$$M/\square = k S^2/2$$

Where: M is applied bending moment; \square is joint rotation; k is the slip modulus for a fastener; and S is spacing between fasteners.

From the preceding equation it is evident that if you double the spacing between fasteners, the rotational stiffness of the connection is increased by a factor of four. Note that each fastener can be replaced by a group of fasteners (e.g., a cluster of nails), and the same equation applied. In this case, k would represent the slip modulus for the fastener group and S the on-center spacing of the two fastener groups

Enhancing rigidity of post-to-truss connections

Designers intent upon achieving a more rigid post-to-truss connection generally use a minimum of two bolts to make the connection. The two bolts are typically spaced as far apart as possible without violating the National Design Specification (NDS) bolt placement requirements (AF&PA, 2005). The requirements, which are given in Table 1, control minimum distance between fasteners and edges and ends of any wood members they join; as well as minimum spacing between bolts and lag screws.

Figure 11 shows four different post-to-truss connections. If the same fasteners were used in each of the four connections, the most rigid would generally be that with the greatest spacing between fasteners. To this end, the connection with the kneebrace (Figure 11a) would have the most rotational stiffness, second best would be the raised heel (Figure 11b), followed by the deep heel truss (Figure 11c) and the regular heel truss without a kneebrace (Figure 11d). Because of the relatively close spacing of the two bolts in Figure 11d, this connection is likely to behave much like a pin connection.

Each truss in Figure 11 rests on a

small wood bearing block that sits on the middle ply of a three-layer post. Sandwiching the truss between outer plies in this manner has the advantage of placing bolts in double shear, which approximately doubles their allowable design shear capacity as shown in Figure 12. The forces listed in this figure are NDS allowable stress design (ASD) values for normal load duration, dry condi-

tions, post and truss specific gravities of 0.55, and a bolt yield strength of 45,000 lbf/in².

With respect to connection geometry, the values assume: (1) fasteners making up the post-to-truss connection are vertically aligned and, (2) edge and end distance requirements in Table 1 have been met. When fasteners are vertically aligned, post plies are loaded perpen-

AT SEALTITE

WE PUT OUR HEADS TOGETHER



TO DRIVE HOME THESE GREAT POINTS



**We Sell More Than Fasteners.
We Sell Solutions.**

Through advanced engineering, our patented fasteners have solved numerous application challenges.

Whether it be a steel-frame or wood-frame building, residential metal roofing, or architectural standing seam, SEALTITE can be your total source for high quality fasteners, foam closure strips & accessories.

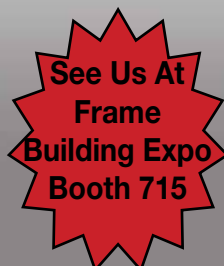

ST
SEALTITE
BUILDING FASTENERS

1-800-352-4864
www.sealtite.com

Circle Reader Service #429

dicular-to-grain and the truss is loaded parallel-to-grain. It is the relatively low perpendicular-to-grain compressive strength of the post plies that dictates fastener failure mode and thus limits connection strength. Placement of post plies on both sides of a truss utilizes these weaker elements more effectively and thus explains the enhanced strength of double shear connections.

Resting a truss on the middle ply (or on a bearing block on the middle ply) results in a more uniform transfer of load into post plies. The double shear connection induces virtually equal bending loads in the outer plies, and these outer plies are both capable of interchanging load with the middle ply (i.e., the ply supporting the truss).

When trusses are placed on an outer ply, the bulk of the load from the truss is transferred into the middle ply, and the middle ply is the only ply that can interchange load with the ply that is supporting the truss.

Some designers try to compensate for this shortcoming by attaching a plate on the outside of the truss as shown in **Figure 13**.

Unfortunately, this plate transfers measurably less bending moment than the full length post plies because of rotation between the post and the plate's lower portion.

Despite that fact that placing a truss on an inner ply produces a better connection, recognize that trusses are most often rested on an outer post ply. There are two reasons for this.

First, sandwiching a truss between outer plies is a practical option only with mechanically-laminated posts (note that there is a mismatch between the width of a truss fabricated with metal plate connectors and the width of a glulam ply).

Second, it is much easier to install a truss on an outer ply. For a post that will be embedded in the ground, the *typical* method of sandwiching a truss between outer plies involves leaving an inner ply short and placing a bearing block between this shortened inner ply and the truss. Bearing block height is determined after the post has been set, and only after the truss has been seated on this block can bolt holes (if needed) be drilled. When a truss is installed on an outer ply, there is no need for special

blocking, and any required bolt holes can be drilled in the truss before it is lifted into place.

Trusses can be placed on an inner ply and bearing blocks eliminated when posts are placed on concrete slabs/walls. This is because any adjustment in truss bearing height can be made by cutting the bottom of the post prior to placing it on the slab/wall.

Bearing blocks are almost always used when posts are embedded. In such cases, a good target height for the bearing blocks is probably between 4 inches and a foot. When you shoot for block heights of only 1 or 2 inches (by minimizing the amount that you shorten the inner ply) post installers must be careful not to leave the post too high in the ground. More specially, they must be careful not to position the top of the inner ply above the eventual truss bearing height as this would require a shortening of the inner ply – a task that I would imagine is somewhat of a pain to get right.

Always extend post plies to the underside of the roof to maximize the vertical distance between the top fastener in a post-to-truss connection and the top of the post plies. Where purlins sit on top of trusses, this means extending the plies above the trusses as shown in **Figures 11 and 13**. This practice reduces the likelihood of a split along the wood grain when bending and uplift forces are acting. It also eliminates the top of the post as a bird nesting location.

Similarly, extend the end of a truss outside of the post to increase the horizontal distance from the end of the truss to the post-to-truss fasteners (see **Figures 11 and 13**). This reduces probability of a wood split in the truss heel when the connection is subjected to bending moments and the fasteners do not penetrate a metal plate connector.

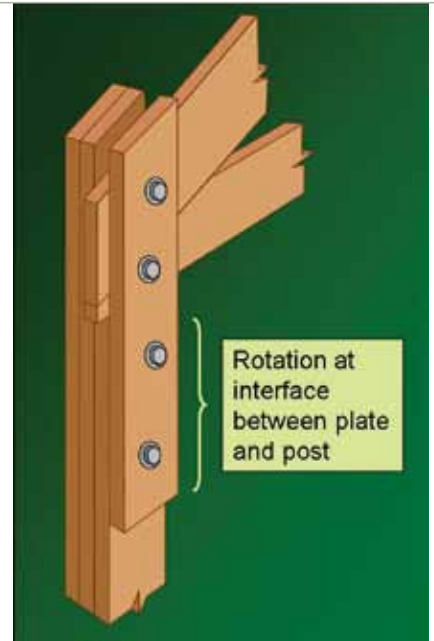
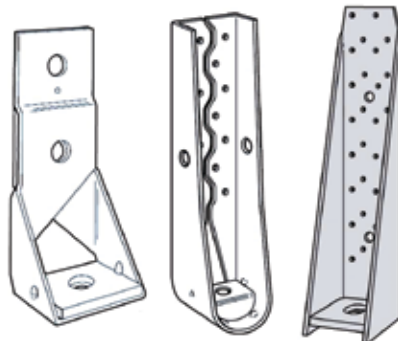

Figure 13. Plate added to help transfer load between truss and post is not as effective in transferring bending moment (i.e., not as effective as the post ply attached directly to the truss) because of rotation between the plate and post.

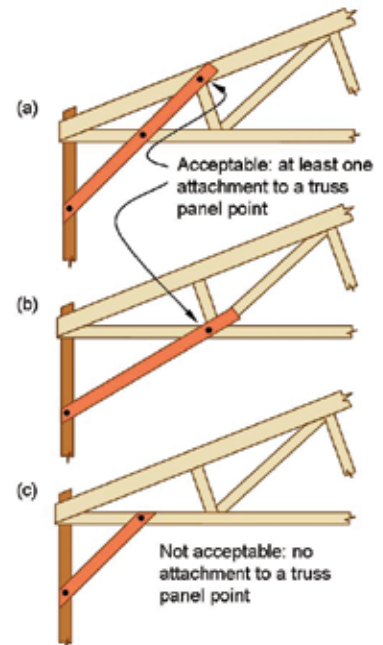

Figure 14. Kneebraces that are not attached to at least one truss panel point can induce bending stresses in a truss chord for which the chord was not designed.

Figure 15. (Left) Commercially available brackets like these can generally be used to transfer post shear and axial forces into concrete. They can't be used to transfer post bending moments into concrete.

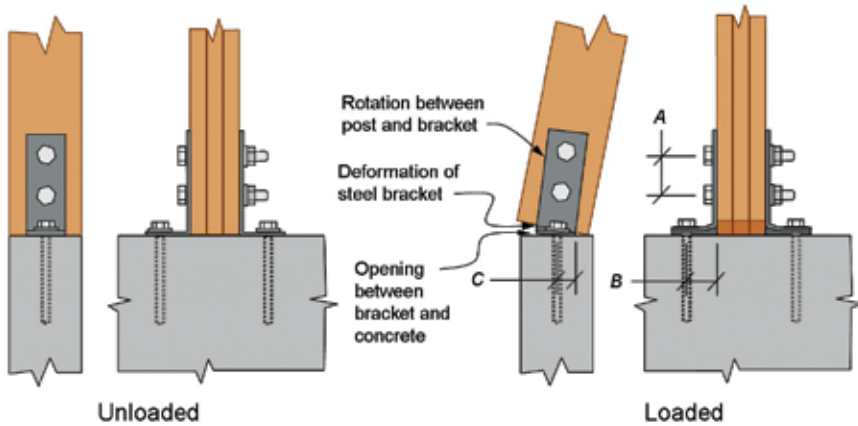

Figure 16. Deformation under bending load of a post-to-concrete anchor like those shown in figure 15.

Where the fastener penetrates a metal plate connector, the likelihood of a wood split occurring in the truss chord is extremely remote.

The top end of a kneebrace should always be attached to a truss panel point on either the upper or lower chord (Figure 14). A kneebrace that is attached between panel points will induce bending stresses into the chord for which it

may not be designed. Along these same lines, it should be emphasized that it is important for truss designers to account for the forces induced by the fasteners that connect the post to the truss. All too often these forces are ignored in truss design, even in situations where a fairly rigid connection will be employed.

The three connections in Figure 11 that utilize bolts are ones that I designed

and fabricated for livestock housing buildings on my brothers farm. For critical structural connections in corrosive environments, I prefer bolts and larger diameter screws over nails and smaller diameter screws. Not only does there tend to be more moisture condensing on fasteners in livestock housing facilities, but the condensate tends to be more acidic because of ammonia and sulfur dioxide that can permeate the air.

Via involvement in litigation associated with balcony failures in the Milwaukee area (Bohnhoff, 2002), I've learned that a surprising amount of fastener corrosion can take place under certain conditions, and in such situations, larger diameter fasteners have a distinct advantage.

Note that if you lose 0.05 inches of material off the surface of a fastener with a 0.13 inch diameter, you only have about 5% of the fastener left, whereas if you lose the same amount off a 0.75 inch diameter fastener, you have 75% of the fastener left. That said, you could

The Warmth & Character of Wood

Horse Stalls
 Custom Barn Doors
 Dutch Doors
 Feeders & Waterers
 Stall Mats & Aisle Pavers
 Cupolas
 Weathervanes

Builder Discounts and "Same Day" Quoting
 Free Catalog and Installation Video



See us in Booth #714
 at Frame Building Expo!

WOODSTAR PRODUCTS, INC.
 1824 HOBBS DRIVE
 DELAVAN WI 53115
 (800) 648-3415 Toll Free
 (262) 728-8460 Voice
 (262) 728-1813 Fax
 stalls@wdstar.com E-Mail



WWW.WDSTAR.COM



Circle Reader Service #483

certainly argue that if conditions are such that fastener corrosion is an issue in your building, then the integrity of metal plate connections (a.k.a. truss plates) with their relatively small teeth is likely to be a much greater concern than the durability of post-to-truss connections.

Unlike other fasteners, bolts provide the ability to clamp components together. That said, the clamping capacity of bolts can quickly disappear as the clamped lumber loses moisture. For this reason, it is good practice to retighten bolts near the end of their first winter in service — the point at which lumber should be at its lowest moisture content level.

The primary disadvantage of using bolts is that poor construction can significantly compromise the quality of the connection. Fasteners must be installed with proper spacings, end and edge distances in accordance with Table 1. This is less likely to occur when larger diameter fasteners are used, and drawings identifying bolt hole location are not available on site. Bolts also require proper hole preparation, which means drilling all the way through from one side of the post.

Section 11.1.2.2 of the 2005 NDS (AF&PA, 2005) requires that holes be a minimum of 1/32 inch to a maximum of 1/16 inch larger than the bolt diameter.

Self-drilling, hex-head wood screws

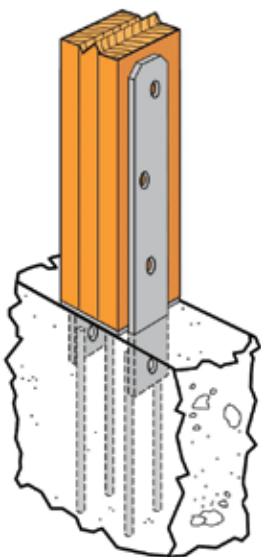

Figure 18. Bracket recommended for enhanced rotational strength and stiffness. For high bending forces replace flat steel plates with steel channels.

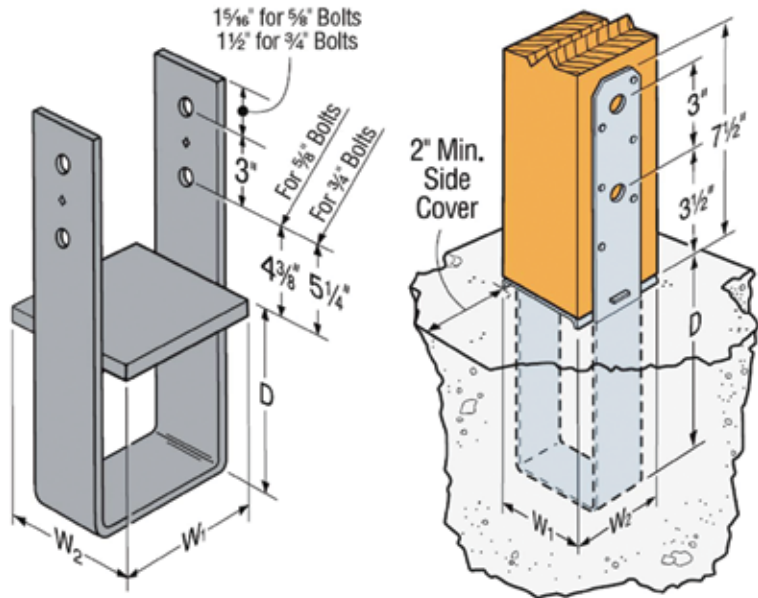

Figure 17. Commercially available wood-to-concrete anchors with more rotational stiffness than those in figure 15.

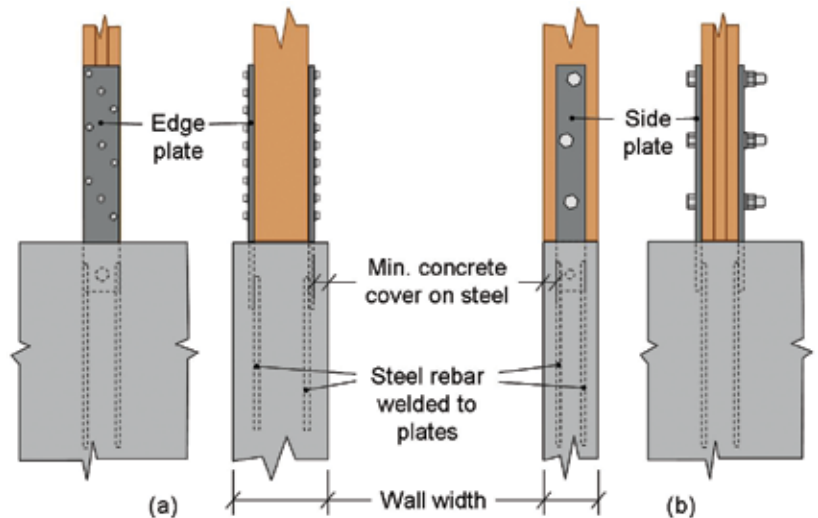

Figure 19. (a) Edge plates transfer bending loads more effectively. (b) Side plates enable use of narrower concrete walls.

with a nominal diameter near 0.25 inches are becoming increasingly popular for truss-to-post connections. These screws have advantages over bolts in that they are quicker to install and overall quality of installation is generally much more uniform as it is not dependent on the quality of pre-bored lead holes.

As with bolts, effective double shear connections can be obtained with self-drilling screws when (1) the truss rests on an inner post ply, and (2) screw length is near equal to post width. Depending on screw thread length, it may be wise to C-clamp post plies to the truss while

installing a self-drilling screw.

The shear capacity of a self-drilling screw is bound to be less than a larger diameter bolt because of the reduced dowel bearing area of smaller diameter fasteners.

To this end, multiple self-drilling screws are generally required to transfer the same amount of load as a large bolt. This is not a problem since smaller diameter fasteners can be spaced closer together and closer to the end and edges of the wood members they connect. It is important to note that when you calculate the amount of load that you



Figure 20. Post-to-concrete wall connection with straight side plates: (a) plate width fixed with two short rebar; (b) top of wall reinforced with horizontal rebar passed through plates; (c) angles and clamps used to fix bracket in place during concrete placement; (d) finished connection.

can transfer with dowel type fasteners spaced at code-allowed minimum distances, you will find that more total load can be transferred per interlayer contact area with smaller diameter fasteners than with larger ones. This is due to the fact that wood bearing strength controls the amount of load a metal fastener can transfer, and allowable wood bearing pressures increase as the width of the bearing contact area decreases.

Enhancing rigidity of post-to-concrete connections

When wood posts are not embedded in the ground, they are almost always connected to concrete in some fashion. This connection invariably involves one or two steel plates or brackets. When assessing the rotational stiffness of a post-to-concrete connection it is important to realize that the load transfer path through the connection involves three different elements:

(1) the connection between the post and steel plate/bracket, (2) the steel plate/bracket itself, and (3) the connection between the concrete and the steel plate/bracket. Since these three elements are in series, measurable flexibility in just one of them means that the entire connection will be relatively flexible and will need to be treated as a pin-type connection.

Many builders use commercially available brackets similar to those shown in **Figure 15** to make their post-to-concrete connections. Although these brackets, if properly sized, will generally do a satisfactory job of transferring axial and shear forces from the post into the concrete, they will provide little, if any transfer of bending moment.

As **Figure 16** shows, connections with these brackets lack rotational stiffness in all three of the previously described elements (and a measurable lack of stiffness in only one of them



Specializing in Products for the Post Frame Industry

THE INDUSTRIES LEADING SUPPLIER AND MANUFACTURER OF . . .

**1015 32nd Ave West
Spencer, Iowa 51301
ph: 800-360-6467
FAX: 800-361-3452
www.mwicomponents.com**

TEMPSHIELD™

CUPOLAS

WEATHERVANES

UNI-VENT II™

BALE DOORS

ARCADIAN SLIDERS

SOFFIT & TRIM

We also supply and manufacture a full line of Ridg-Vents®, Premium Dutch Doors, polycarbonate and PVC panels, Horse Stall Components, three profiles of Slide Frame and an extensive line of sliding door track and hardware.

LOOK FOR OUR BOOTH #223 AT THE 2009 FRAME BUILDING EXPO
FEBRUARY 25 - 27 IN NASHVILLE

Circle Reader Service #308

renders the connection a pin type connection).

First, the spacing of fasteners connecting the post and bracket (dimension A in **Figure 16**) is generally way too close resulting in significant slip between the post and bracket. Second, the horizontal distance between the post and concrete anchor (dimension B in **Figure 16**), combined with a relatively thin bracket material, results in measurable twisting/deformation of the bracket.

Third, the distance between the concrete anchor and the edge of the bracket (dimension C in **figure 16**), represents the moment arm that forms to transfer bending moment from the bracket to the concrete. The shortness of this distance produces a high tension force in the anchor and high contact pressure at the edge of the bracket. When combined with a relatively thin bracket material, the end result is a rotation of the bracket relative to the surface of the concrete.

An improvement over the brackets shown in **Figure 15** is the commercially available product shown in **Figure 17**. By extending plates directly into concrete, dimension B in **Figure 16** is reduced to zero, significantly reducing deformation of the steel. Additionally, anchoring the plates as shown essentially eliminates deformation associated with load transfer from the plates to the concrete. The major deficiency with the **Figure 17** bracket is that the spacing between the bracket-to-post fasteners is still too close to provide measurable rotational rigidity.

In place of the product shown in **Figure 17**, I recommend the design in **Figure 18**, or a slightly modified version of it. The plates in this design are thicker and extend further up the post than those in **Figure 17**.

Efficient load transfer between the plates and concrete is achieved by welding steel reinforcing bars to the outside edges of the plates at a location starting just below the surface of the concrete. These rods take bending forces out of the outside edges of the plate — the location where the stresses are highest. Holes located in the plates just below the concrete surface facilitate the placement of a horizontal rebar in the top of the wall. In situations where a significant amount of bending moment transfer is needed, the



Figure 21. Post-to-concrete pier connection featuring straight side plates welded to steel reinforcing bars. Threaded rod with coupler nuts and bolts used to: (a) fixed bracket into place, (b) attach temporary wood braces to pier, and (3) provide anchoring points (at a 28 inch spacing) for steel partitions and gates.

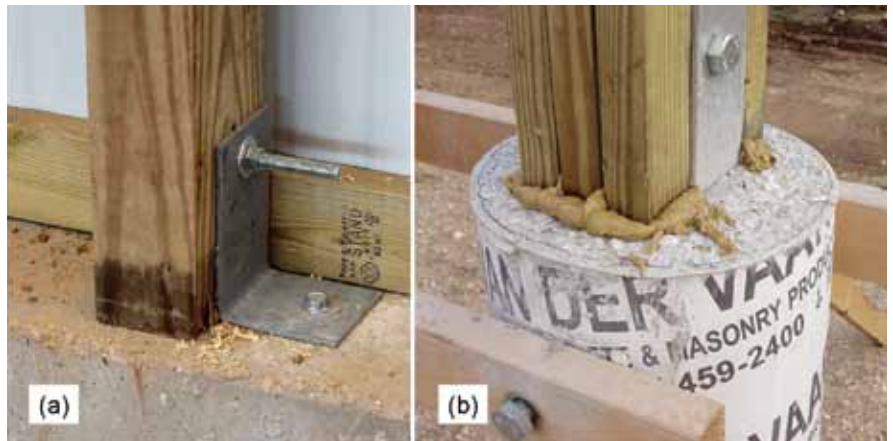

Figure 22. Post-to-concrete connections (a) without moisture barrier between post and concrete, and (b) with polyurethane placed between concrete and post to limit water vapor and liquid diffusion into post base.

flat side plates should be replaced with channels and attached with additional fasteners.

Although plates on post edges (**Figure 19a**) enable the most direct transfer of bending moment from the post into the concrete, plates are generally placed on the sides (**Figure 19b**) because (1) such plates do not interfere with attachment of materials on post faces, and (2) the supporting concrete wall or pier can be narrower. The latter advantage is due to the fact that structural reinforcing elements within concrete are required to have a minimum amount of cover.

For cast-in-place concrete, this minimum cover is 2 inches for No. 6 or larger bars and 1.5 inches for No. 5 or smaller bars (ACI, 1999). Minimum concrete cover on reinforcement in precast concrete components is 1.5 inches for No. 6 or larger bars and 1.25 inches for No. 5

or smaller bars.

Figure 20 contains four images of a post-to-concrete wall connection that I used on my brother's calf barn. The goal in this particular application was to provide a connection with fairly decent rigidity that was relatively inexpensive, easy to fabricate, and enabled a quick and accurate installation.

Two short rebars were used to fix plate spacing and to help lock the plates into position within the concrete (**Figure 20a**). A continuous run of rebar located in the top of the wall was passed through the hole located between the two short rebar in each plate (**Figure 20b**). Temporary angles and clamps were used to lock the bracket into position during concrete placement (**Figure 20c**).

Figures 21 and 22b are of a more elaborate post-to-pier connection that I

used on my brother's heifer barn. This connection features rebar welded to plates as illustrated in **Figure 18**. Two sets of small plates were welded to these rebar and a threaded rod passed through each of the sets to help fixture the entire bracket into place prior to concrete placement.

The upper set of plates (with the threaded rod installed) is visible in **Figure 21a**. The lower set of plates and corresponding threaded rod are located about 28 inches below the top set (**Figure 21c**). Hex coupling nuts were turned onto each end of both threaded rods. Machine bolts were then inserted through holes drilled in the cardboard forming tube, and turned into the hex nuts to lock the bracket into place. Temporary wood braces that ran from pier to pier were held in place with these bolts. These same bolts are used in the finished structure to attach partitions and swinging gates to the piers. Overall, the brackets were easy to fabricate and install, and they provide for a sound connection in addition to facilitating attachment of other items to the concrete piers.

The 20-inch spacing between top and bottom plate-to-post fasteners in **Figure 21c** is at a level needed to control rotational slip between the plate and post. The size of the plates was selected so that the maximum design bending strength of the side plates was reached when the maximum capacity of a bolt connection was reached. That said, the design bending strength of the two side plates is about half the design bending strength capacity of the post. Consequently, a more balanced design, and one capable of handling all that the post could transfer, would feature a bracket of thicker and/or wider plates or steel channels, and a simultaneous increase in the number of plate-to-post fasteners.

Figure 22a demonstrates how concrete will feed moisture into the end of lumber that is in direct contact with the concrete. For this reason, codes require that lumber in contact with concrete should be preservative-treated or an impervious material should be placed between the wood and concrete. The column resting on the wall in **Figure 20d** is not preservative-treated. In this particular case, I set the column in a bed of one-part moisture curing polyurethane (PL's Construction Adhesive). The polyurethane expands slightly as it cures; I trim off excess from around the post after it cures. Although the columns that I set on the piers were preservative-treated, I also set them in a bed of polyurethane as shown in **Figure 22b** (this photo was obviously taken prior to trimming off excess material). While plastic cut from a milk jug (i.e., high density polyethylene or HDPE) would function as an excellent moisture barrier, the polyurethane adhesive that I used has the added advantage that it conforms to uneven concrete and wood surfaces, and it does not allow water to seep between the post and concrete. To this end, I would contend that you could not go wrong with the combination of HDPE from a milk jug and polyurethane adhesive.

I personally believe that plastics between wood and concrete are preferred to metal. The high thermal conductivity of metal results in more condensation of water at the interfaces between both the steel and wood and the steel and concrete. Note that the problem with condensation of water around mechanical fasteners is believed to be a factor that contributes to accelerated corrosion of the fasteners, especially in more acidic wood species such as Doug Fir (Bohnhoff, 2002). I would also not prefer

to use unprotected steel in a high moisture content environment or a high acidic environment (e.g., animal housing). Since the untreated column in figure 20d is one of many that I set in polyurethane in my brother's calf barn, I will eventually find out how this system works in a fairly harsh environment.

Summary

Factors affecting the rigidity of connections were overviewed and examples of steps that can be taken to increase the rotational stiffness of connections presented. Chief among these is an increase in the spacing of fasteners that make up a connection. When connecting posts to concrete, it is beneficial to attach the post to straight plates or channels that extend directly into the concrete. ■

References

- AF&PA. 2005. National Design Specifications for Wood Construction. American Forest & Paper Association American Wood Council, Washington, DC 20036
- Bohnhoff, D.R. 2002. Hidden danger. Wood Design Focus. 12(1):19-25.
- ACI. 1999. ACI 318-99 Building Code Requirements for Structural Concrete. American Concrete Institute, Farmington Hills, MI 48333.



BAY INSULATION CO.
MEMBER OF THE BAY INDUSTRIES CORPORATE FAMILY

With 24 plants nationwide, Bay Insulation is among the largest suppliers of insulation for the post-frame industry.

BAY INSULATION Offers:

- ◆ Custom faced fiberglass
- ◆ Unfaced fiberglass
- ◆ TVM radiant barrier
- ◆ Thermax Rigid Board
- ◆ Expi-Door fire rated walk-doors

Come visit us at Booth #323 at the Frame Builders Expo in Nashville

www.bayinsulation.com

Circle Reader Service #692