

# Changes in the 2001 NDS<sup>®</sup> for Wood Construction

By Philip Line, P.E.  
 Dr. Robert Taylor, P.Eng.  
 John "Buddy" Showalter, P.E.  
 Bradford K. Douglas, P.E.

## Introduction

The 2001 Edition of the National Design Specification<sup>®</sup> for Wood Construction has been published and is available from the American Forest & Paper Association's American Wood Council. Publication of the 2001 NDS culminates three years of development by AF&PA's NDS Canvass Committee dedicated to providing state-of-the art information for wood design. The 2001 NDS was approved as an American National Standard on Nov. 30, 2001, with a designation ANSI/AF&PA NDS-2001.

The 2001 NDS contains many changes from the previous edition, which are summarized in this article. Some significant changes include:

## New

- product chapters (prefabricated wood I-joists, structural composite lumber, wood structural panels, and poles)
- appendix for local stresses in members at connections
- chapter for shear walls and diaphragms
- chapter for fire design

## Revised

- provisions for shear design (coinciding with increased shear design values)
- provisions for notching
- provisions for end grain bearing
- volume factor for glued laminated timber
- connection design provisions
- connection tables

The NDS Supplement: Design Values for Wood Construction, an integral part of the NDS, has also been updated to provide the latest design values for lumber and glued laminated timber.

## New Products

Three new product chapters have been added: Structural Composite Lumber, Wood Structural Panels, and Prefabricated Wood I-joists. These chapters parallel the format of chapters for sawn lumber and glued laminated timber. Product definitions, identification, design value adjustments, and special design considerations have been provided. To

clarify applicability of adjustments for each product type, separate tables have been developed for each product chapter in the NDS. An example of one of these tables is provided in Table 1.

	Load Duration Factor	Wet Service Factor	Temperature Factor	Beam Stability Factor	Size Factor	Flat Use Factor	Incising Factor	Repetitive Member Factor	Form Factor	Column Stability Factor	Backing Stiffness Factor	Bearing Area Factor
$F_b = F_b \times$	$C_D$	$C_M$	$C_t$	$C_L$	$C_F$	$C_{Fu}$	$C_i$	$C_r$	$C_T$	-	-	-
$F_t = F_t \times$	$C_D$	$C_M$	$C_t$	-	$C_F$	-	$C_i$	-	-	-	-	-
$F_v = F_v \times$	$C_D$	$C_M$	$C_t$	-	-	-	$C_i$	-	-	-	-	-
$F_{c*} = F_{c*} \times$	-	$C_M$	$C_t$	-	-	-	$C_i$	-	-	-	-	$C_b$
$F_c = F_c \times$	$C_D$	$C_M$	$C_t$	-	$C_F$	-	$C_i$	-	-	$C_P$	-	-
$E = E \times$	-	$C_M$	$C_t$	-	-	-	$C_i$	-	-	-	$C_T$	-

Table 1. Applicability of Adjustment Factors for Sawn Lumber (reprinted with permission from the American Forest & Paper Association, Inc.)

Design information for construction poles has been added and combined with an existing chapter on piles. Like other product chapters, the new chapter titled Round Timber Poles and Piles contains information such as applicable product standards and standard adjustments to design values. Construction pole design values per ASTM D3200 have also been added.

Note: Design values for utility poles are developed using ANSI O5.1. If used as construction poles with NDS provisions, these poles must be regraded in accordance with ASTM D3200.

## Member Design — Shear

Review of ASTM procedures used to establish allowable shear stresses revealed that shear values were being reduced by two separate factors for effects of splits, checks, and/or shakes. One of these adjustments was made to the base value, the other was an adjustment to design values for grade effects. In 2000, ASTM standard D245 was revised to remove one of these adjustments, which resulted in an increase of nearly two for allowable shear design values; however, grade effect adjustments were eliminated.

In the 2001 NDS Supplement, shear design values for sawn lumber are generally 1.95 times higher than values printed in the 1997 edition in response to the change in D245. With this change, shear-related provisions in the NDS were re-evaluated and modified where necessary to provide

appropriate designs. Changes include:

- Removal of the shear strength increase factor,  $C_H$ , which previously permitted shear design values to be increased based on limited occurrences of splits, checks, and shakes.

- Revised provisions for ignoring shear loads near supports as follows:

3.4.3.1 (a) For beams supported by full bearing on one surface and loads applied to the opposite surface, uniformly distributed loads within a distance from supports equal to the depth of the bending member,  $d$ , shall be permitted to be ignored. For beams supported by full bearing on one surface and loads applied to the opposite surface, concentrated loads within a distance,  $d$ , from supports shall be permitted to be multiplied by  $x/d$  where  $x$  is the distance from the beam sup-

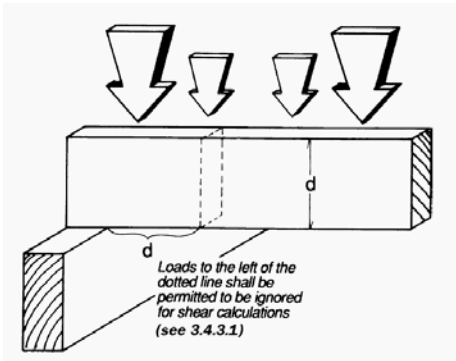

port face to the load (see Figure 1).

Figure 1. Shear at supports. (reprinted with permission from the American Forest & Paper Association, Inc.)

- Revised provisions for shear strength at notches (where permitted). Changes include addition of the squared component on the strength reduction term and reformat of the shear equation in an “allowable shear” format versus the “actual shear stress” format in the 1997 edition. New provisions of the 2001 NDS for notching are shown below. A comparison to 1997 provisions is provided in Figure 2.

Notches: 3.4.3.2. (a) For bending members with rectangular cross section and the tension allowable  $V_r'$ , shall be calculated as follows:

$$V_r' = \left[ \frac{2}{3} F_v' b d_n \right] \left[ \frac{d_n}{d} \right]^2$$

- Revised provisions for shear strength at connections less than  $5d$  from member ends. Changes parallel those made

$$V_r' = \left[ \frac{2}{3} F_v' b d_e \right] \left[ \frac{d_e}{d} \right]^2$$

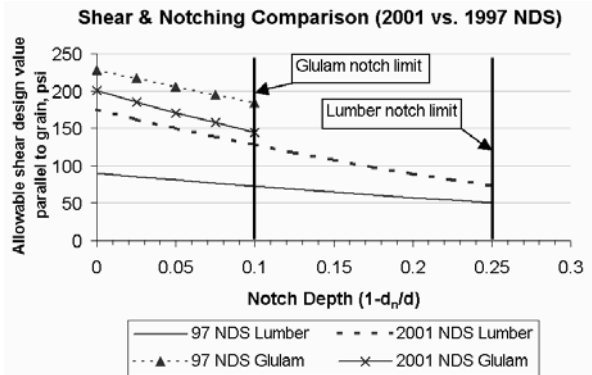

Figure 2. Comparison of shear and notching provisions for 2001 versus 1997 NDS.

for notched bending members:

Connections: 3.4.3.3. (a) When the connection is less than five times the depth,  $5d$ , of the member from its end, the allowable design shear,  $V_r'$ , shall be calculated as follows:

- Removal of 50 percent shear increases when connections are more than  $5d$  from the member end.

- Removal of two-beam shear provisions which permitted load reductions for shear design of single span sawn lumber bending members. This provision was linked with assumptions used to develop previous shear design values and is no longer applicable.

## End Grain Bearing

End grain bearing values,  $F_{g_e}$ , are no longer tabulated in the NDS Supplement. Instead, provisions of the NDS specify use of compression parallel to grain design values for end grain bearing (bearing parallel to grain) as follows:

3.10.1.1 The actual compressive bearing stress parallel to grain shall be based on the net bearing area and shall not exceed the tabulated compression design value parallel to grain multiplied by all applicable adjustment factors except the column stability factor,  $f_c \leq F_c^*$ .

For dimension lumber, compression parallel to grain design values,  $F_c$ , are generally higher than bearing design values,  $F_g$ . For timbers,  $F_g$  is typically higher than  $F_c$ . This results in a small capacity increase for higher grade dimension lumber, while timbers and lower grade dimension lumber capacities are lower.

## Notching

Recommendations to avoid notching wherever possible are continued in the 2001 NDS. For sawn lumber, permitted notch locations and notch depths remain unchanged (see Figure 3) but clarification is added that interior notch limits and locations are applicable to single span bending members.

For glued laminated timber, an upper limit of 3 in. has

been added for tension side end notches as follows:

5.4.4.1 The tension side of glued-laminated timber bending members shall not be notched, except at ends of members for bearing over a support, and notch depth shall not exceed the lesser of 1/10 the depth of the member or three inches...

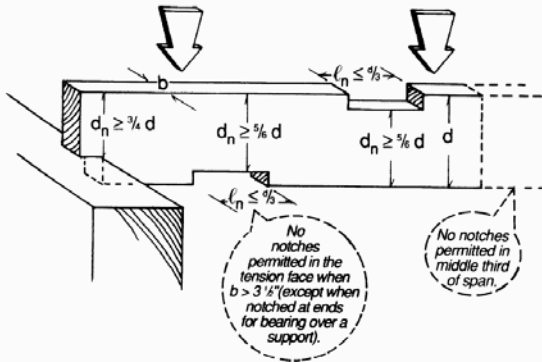

Figure 3. Notch limitations for sawn lumber beams. (reprinted with permission from the American Forest & Paper Association, Inc.)

The 3 in. limit was developed in response to preliminary research which supported current shear strength provisions for notched beam depths up to 30 in.

### Volume Factor

The loading condition coefficient,  $K_L$ , has been removed from calculation of the volume factor. The  $K_L$  factor comes from provisions of ASTM D3737 where it is used to statistically adjust certain load cases when developing design values from glulam test data. This simplification was considered to be appropriate since the  $K_L$  factor was only available for a few idealized loading conditions and the overall range in adjustment is small. For glulam, removal of this coefficient will result in a 9 percent reduction and 4 percent increase in capacity for the single concentrated load case and third-point load case, respectively.

### Connections — Local Stresses

Provisions for stresses in members at connections have been clarified in the 2001 NDS. Provisions have been rewritten as follows:

10.1.2 Structural members shall be checked for load carrying capacity at connections in accordance with all appli-

**When Style & Economy Matter...**

Count on  
**AJ Manufacturing**

**Improve the Appearance of Your Next Building... Use AJ Manufacturing Rollformed Doors**

- Rolled edges for style & strength
- Polyurethane foam core
- Prepainted with two coats polyester paint
- R-12 insulation value
- 1 3/4" door panel
- 2'4" - 4'0" widths standard

AJ Manufacturing, Inc.  
1-800-328-9448 | 715-568-2204  
1217 Oak Street | Bloomer, Wisconsin 54724  
fax: 715-568-3099 | email: sales@ajdoor.com

Circle Reader Service #1436

**Get it Done Faster & Safer with the Tele-Boom!**

"This piece of equipment has improved the production of our crews and made the job site a safer place!" Mike Zawada - Zawada Brothers Construction

Easy Hook-up to most popular skid steer loaders  
Just one Hydraulic Outlet • Safely reaches from 8'6" - 30'  
Proven in the field to Save Time and Money!

Take a look at our Web site for additional accessories!  
www.sheyennemfg.com

**Sheyenne Tooling & Mfg.** **800-797-1883**

7th & Lenham Ave., PO Box 647, Cooperstown, ND 58425  
Fax: 701-797-2584

Circle Reader Service #554



cable provisions of this standard including 3.1.2, 3.1.3, and 3.4.3.3. Local stresses in connections using multiple fasteners shall be checked in accordance with principles of engineering mechanics. One method for determining these stresses is provided in Appendix E.

Appendix E — Local Stresses in Fastener Groups is new to the 2001 NDS and provides one method to evaluate capacity of a fastener group limited by wood related failure mechanisms. Example problems are added to demonstrate application of Appendix E provisions for checking net section tension capacity, row tear-out capacity, and group tear-out capacity. These provisions are applicable to all previous editions of the NDS.

## Connections — Dowel-type Fasteners

Separate chapters for design of bolts, lag screws, wood screws, and nails have been consolidated into a single chapter in the 2001 edition entitled “Dowel-type Fasteners (Bolts, Lag Screws, Wood Screws, Nails/Spikes, Drift Bolts and Drift Pins).” The new format was introduced to provide a consistent method for determining lateral strength of dowel-type fasteners and minimize duplication of design provisions.

Significant changes that improve consistency and minimize duplication of provisions include:

- One set of yield mode equations, describing behavior of dowels under lateral loads, is provided for all dowel-type fasteners. A requirement to check all yield modes is coupled with removal of the penetration depth factor,  $C_d$ . In previous NDS versions, different yield limit equations were used for lag screws, wood screws and nails and penetration depth factors were used in lieu of checking all yield mode equations.

- Capacity reduction terms are based on fastener diameter rather than fastener type. For fasteners with diameter,  $D$ , greater than or equal to 1/4 in. ( $D \geq 1/4$  in.), strength reductions vary by yield mode and are consistent with reductions used for bolts in the 1997 edition. For  $D < 1/4$  in., strength reduction terms vary linearly with diameter and are consistent with reductions used for nails in the 1997 edition.

- Differences in dowel bearing strength parallel and perpendicular to grain are recognized when  $D \geq 1/4$  in. Previously, differences in dowel bearing strength parallel and perpendicular to grain were not recognized for nails and wood screws.

- Revisions of the group action factor to be applicable to dowel-type fasteners with  $D \geq 1/4$  in. For fasteners with  $D < 1/4$  in., the group action factor is taken as 1.0.



## Glu-Lam Posts

...another quality product from

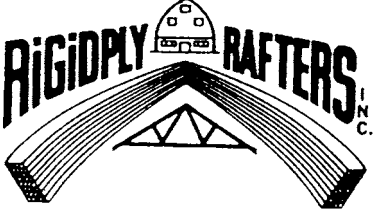







Active Member





MEMBER



### Manufacturers and Suppliers of

- GLU-LAM TREATED POSTS
- ROOF & FLOOR TRUSSES
- GLU-LAM ARCHES
- GLU-LAM BEAMS
- T&G AND V-GROOVE DECKING
- COMPLETE LINE OF POST FRAME BUILDING MATERIALS
- CRANE SERVICE

**Richland, PA 717-866-6581**  
**Oakland, MD 301-334-3977**

Circle Reader Service #327

Other changes to connection provisions:

- Dowel bearing strengths for steel side members, used to develop wood-to-steel connection values, are increased to be consistent with AISC and AISI standards.

$$Z'_\theta = \frac{Z'_\parallel Z'_\perp}{Z'_\parallel \sin^2 \theta + Z'_\perp \cos^2 \theta}$$

- Appendix J is expanded to include Hankinson's Formula for determining bolt or lag screw connection design values,  $Z$ , from tabular values, when members are loaded at an angle to grain between 0° and 90°. The new equation is as follows:

- Appendix L is expanded to include figures and typical dimensions for bolts, lag screws, wood screws, and nails. For lag screws, a footnote is revised to clarify that tabulated thread lengths represent minimum thread lengths for lag screws. Figures of cut thread and rolled thread wood screws show differences between types of wood screws and tabular information identifies wood screws by "number" rather than "gage" used in previous editions.

- Root diameter,  $D_r$ , is used to calculate lag screw and wood screw lateral connection capacity, unless a more detailed analysis is performed to account for the varying moment capacity of the fastener.

- Minimum penetration for wood screws loaded laterally is increased to 6D for consistency with requirements for nails since the tapered tip is included in the penetration length. The change is also more consistent with connections made with lag screws where the tip is not included in the penetration length.

- Removal of tabulated design values for threaded hardened nails since this nail type is not specifically standardized

## Connections — Tabulated design values

Tabulated design values for dowel-type fastener connections have been revised to be consistent with changes in calculation design provisions. Bolt, lag screw, wood screw and nail connection tables include structural composite lumber sizes. Nail connection tables have been expanded to include connections with wood structural panel side members. Added footnotes to nail, lag screw, and wood screw connection tables provide a simple and conservative method for determining design values for connections with reduced penetration.

For bolted connections between wood members, tabulated design values remain unchanged from the 1997 edition. Bolted wood-to-steel connection strengths have increased slightly compared to the 1997 edition due to increased bearing strength of steel. Similarly, nailed wood-to-steel connection strength also increased when compared to the 1997 edition.

Tabulated design values for lag screws are based on a "reduced body diameter" lag screw and tabulated values for wood screws are based on "rolled thread" wood screws. Because "reduced body diameter" lag screws and "rolled thread" wood screws have a shank diameter approximately equal to the root diameter, design values for these fasteners are smaller than those provided in the 1997 edition for "full body diameter" lag screws and "cut thread" wood screws. This change in basis was implemented to better address use of reduced body diameter fasteners and the condition where the full length of the fastener is threaded.

## Shear Walls and Diaphragms

A new chapter on shear walls and diaphragms covering general requirements for framing members, fasteners, and sheathing has been added to parallel similar language in AF&PA/ASCE 16 Standard for Load and Resistance Factor Design (LRFD) for Engineered Wood Construction.

## Fire Design

A new chapter on fire design of exposed wood members has been added. Provisions include procedures that can be used to calculate fire endurance of tension, compression and bending members and members subjected to combined loading. Special provisions for glued laminated timber beams are incorporated as well.

## NDS Supplement

Design provisions in the 2001 NDS are integral with design values in the 2001 NDS Supplement. As such, it is not appropriate to mix design values and provisions from different editions of the NDS. The 2001 NDS Supplement contains increased shear design values for sawn lumber to reflect

Wood Structural Panel	Specific Gravity G	Dowel Bearing Strength, $F_e$ , in Pounds Per Square Inch (psi)
Plywood		
Structural 1, Marine	0.50	4650
Other Grades <sup>1</sup>	0.42	3350
Oriented Strand Board		
All Grades	0.50	4650

1. Use  $G = 0.42$  when species of the plies is not known. When species of the plies is known, specific gravity listed for the actual species and the corresponding dowel bearing strength may be used, or the weighted average may be used for mixed species.

Table 2. Dowel Bearing Strengths for Wood Structural Panels (reprinted with permission from the American Forest & Paper Association, Inc.)

in ASTM F1667.

- Dowel bearing strengths are added for wood structural panels (see Table 2).

changes in ASTM D245 and provisions of the 2001 NDS have been revised to address these increases. Other changes in the 2001 NDS Supplement include addition of design value tables for non-North American dimension lumber and expanded design value tables for mechanically graded dimension lumber.

For glued laminated timber, revised tables for glued laminated hardwood timber design values are provided in a format consistent with tables for softwood glued laminated timber. For softwood glued laminated timber, a consolidated table of design values grouped by stress class is provided in addition to the familiar combination symbol tables from the 1997 edition. Increased shear design values for prismatic members are tabulated. For notched members and certain other conditions, reduction in design values is required as specified in table footnotes.

## NDS Commentary

The Commentary to the 1997 and earlier editions of the NDS will be posted to the AWC Web site for free access. Once an update to the Commentary for the 2001 NDS is complete, it will be included on the AWC Web site as well.

## 2001 NDS and the Model Codes

The 2001 NDS will be the reference document for allowable stress design of wood construction in the 2003 edition of the International Building Code, 2002 edition of ASCE 7 — Minimum Design Loads for Buildings and Other Structures, and the 2002 edition of NFPA 5000 Building Code.

## ASD Manual

The Allowable Stress Design Manual for Engineered Wood Construction, containing additional product supplements (lumber, glulam, poles & piles, panels, shearwalls & diaphragms, and wind/seismic provisions) and product guidelines (I-joists, SCL, trusses, and hangers) along with the 2001 NDS and NDS Supplement, has also been revised and updated. To order a copy of the 2001 ASD Manual, contact the AWC Publications Department at 1-800-890-7732, or visit the AWC Web site at [www.awc.org](http://www.awc.org) for online ordering information.

## eCourses

Additional details regarding changes to the 2001 NDS is available in slide presentation format at [www.awc.org](http://www.awc.org). The specific location is under Outreach/eCourses, and the course number is STD103. ■